

1 FEATURES

- Miniature package
- Low noise
- Low bias instability
- Excellent performance in vibration and shock environments
- 9 axes offered in same package
 - Electronically calibrated axis alignment
- Gyros based on Sensoror ButterflyGyro™
 - Single-crystal silicon technology
 - No intrinsic wear-out effects
- High stability accelerometers and inclinometers
- Insensitive to magnetic fields
- Full EMI compliance
- Digital interface, RS422
- Fully configurable
- Continuous self-diagnostics
- RoHS compatible



(38.6mm x 44.8mm x 21.5mm)

2 GENERAL DESCRIPTION

STIM318 is an IMU consisting of 3 high accuracy MEMS-based gyros, 3 high stability accelerometers and 3 high stability inclinometers in a miniature package. Each axis is factory-calibrated for bias, scale-factor and compensated for temperature effects to provide high-accuracy measurements in the temperature range -40°C to +85°C. The unit runs off a single +5V supply.

STIM318 communicates via a standard high-level RS422 interface. The use of a 32-bit RISC ARM microcontroller provides flexibility in the configuration, like choice of output unit, sample rate, low pass filter -3dB frequency and RS422 bit-rate and protocol parameters. All configurable parameters can be defined when ordering or set by customer.

When STIM318 is powered up, it will perform an internal system check and synchronize the sensor channels. As an acknowledgement of the complete power-up sequence, it will provide special datagrams containing part number, serial number, configuration and bias trim offset data. STIM318 will then automatically proceed to provide measurement data. Connect power and STIM318 will provide accurate measurements over the RS422 interface.

The measurement data is transmitted as packages of data on a fixed format (datagram) at intervals given by the sample rate together with a synchronization signal (TOV). The datagram is in binary coded format in order to have an efficient transfer of data. In addition to the measurement data itself, the datagram contains an identifier, status bytes and a 32 bit CRC (Cyclic Redundancy Check) to provide high degree of fault detection in the transmissions. The status bytes will flag any detected errors in the system. STIM318 can also be configured to transmit data only when triggered by a separate digital input signal (ExtTrig).

For more advanced users, the IMU may be put in Service Mode. In this mode all the configuration parameters can be intermediately or permanently changed by overwriting the current settings in the flash memory. In Service Mode the commands and responses are in a human readable format (ASCII); to enable the use of terminal-type software during typical product integration. Service Mode also provides the ability to perform single measurements, perform diagnostics and obtain a higher detail level of detected errors reported in the status bytes.

Finally, STIM318 may be put in Bias Trim Offset Mode. In this mode the user may trim the biases of all nine axes individually. The bias offsets can be stored in the flash memory to remain in effect after powering off the IMU.

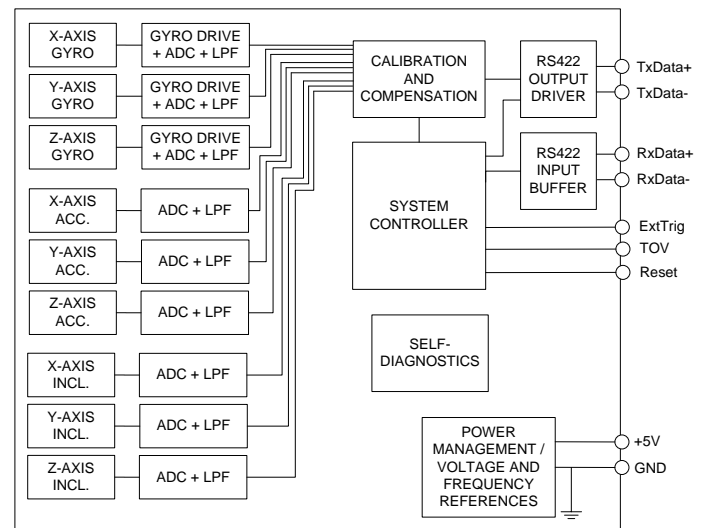

Figure 2-1: STIM318 FUNCTION BLOCK DIAGRAM

3 TABLE OF CONTENTS

DOCUMENT HISTORY	1
1 FEATURES	1
2 GENERAL DESCRIPTION	1
3 TABLE OF CONTENTS	2
4 DEFINITIONS AND ABBREVIATIONS USED IN DOCUMENT	4
4.1 Definitions	4
4.2 Abbreviations	4
5 ABSOLUTE MAXIMUM RATINGS	4
6 SPECIFICATIONS	5
6.1 TYPICAL PERFORMANCE CHARACTERISTICS	10
6.1.1 GYRO CHARACTERISTICS	10
6.1.2 ACCELEROMETER CHARACTERISTICS	14
6.1.3 INCLINOMETER CHARACTERISTICS	17
6.2 Configurable parameters	20
6.3 Datagram specifications	21
6.3.1 Part Number datagram	21
6.3.2 Serial Number datagram	22
6.3.3 Configuration datagram	23
6.3.4 Bias Trim Offset datagram	26
6.3.5 Extended Error Information datagram	27
6.3.6 Normal Mode datagram	28
6.3.7 Cyclic Redundancy Check (CRC)	29
6.4 Status byte	30
7 MECHANICAL	31
7.1 Mechanical dimensions	31
7.2 Advice on mounting orientation	32
7.3 Pin configuration	32
7.4 Definition of axes	32
8 BASIC OPERATION	33
8.1 Reset	33
8.2 External Trigger	33
8.3 Time of Validity (TOV)	34
8.4 Operating modes	35
8.4.1 Init Mode	36
8.4.2 Normal Mode	36
8.4.3 Service Mode	43
8.4.4 Bias Trim Offset Mode	43
8.5 Self-diagnostics	44
9 COMMANDS IN NORMAL MODE	45
9.1 N (PART NUMBER DATAGRAM) command	45
9.2 I (SERIAL NUMBER DATAGRAM) command	45
9.3 C (CONFIGURATION DATAGRAM) command	46
9.4 T (BIAS TRIM OFFSET DATAGRAM) command	46
9.5 E (EXTENDED ERROR INFORMATION DATAGRAM) command	46
9.6 R (RESET) command	46
9.7 SERVICEMODE command	47
9.8 BTOMODE command	48
10 COMMANDS IN SERVICE MODE	49
10.1 i (INFORMATION) command	50
10.2 a (SINGLE-SHOT MEASUREMENT) command	55
10.3 c (DIAGNOSTIC) command	57
10.4 d (DATAGRAM FORMAT) command	59
10.5 t (TRANSMISSION PARAMETERS) command	60
10.5.1 User-defined bit-rate	60
10.6 r (LINE TERMINATION) command	62
10.7 u (OUTPUT UNIT) command	63
10.8 f (LP FILTER -3dB FREQUENCY) command	64
10.9 m (SAMPLE RATE) command	66
10.10 g (GYRO G-COMP) command	67

10.11	b (BIAS TRIM OFFSET) command	70
10.12	s (SAVE) command	72
10.13	x (EXIT) command.....	73
10.14	z (RESTORE TO FACTORY SETTINGS) command.....	75
10.15	? (HELP) command	77
11	COMMANDS IN BIAS TRIM OFFSET MODE	83
11.1	Acknowledgement for entering Bias Trim Offset Mode	83
11.2	Command protocol for Bias Trim Offset Mode	83
11.2.1	Command string.....	83
11.2.2	Response string	83
11.2.3	Checksum	83
11.2.4	Command status codes	84
11.3	Info commands	85
11.3.1	\$ibto	85
11.3.2	\$isv	85
11.3.3	\$irf	86
11.3.4	\$isn.....	86
11.3.5	\$ix.....	86
11.4	Programming commands	86
11.4.1	\$sdbto	87
11.4.2	\$sbto	88
11.4.3	\$srf	88
11.5	General commands	89
11.5.1	\$save.....	89
11.5.2	\$xn.....	89
12	MARKING	90
13	CONFIGURATION / ORDERING INFORMATION.....	91

4 DEFINITIONS AND ABBREVIATIONS USED IN DOCUMENT

4.1 Definitions

$g_0 = 9.80665 \text{m/s}^2$ (standard gravity)

4.2 Abbreviations

Table 4-1: Abbreviations

ABBREVIATION	FULL NAME
BCD	Binary Coded Decimal
CIC-filter	Cascaded Integrator-Comb filter
CR	Carriage Return
ESD	Electro-Static Discharge
ExtTrig	External Trigger
GND	Ground
LF	Line Feed
LP filter	Low-Pass filter
NRST	Negative (active) Reset
rms	root mean square
RxD	Receive Data
TOV	Time of Validity
TxD	Transmit Data
VSUP	Voltage supply

5 ABSOLUTE MAXIMUM RATINGS

Stresses beyond those listed in Table 5-1 may cause permanent damage to the device.

Exposure to any Absolute Maximum Rating condition for extended periods may affect device reliability and lifetime.

Table 5-1: Absolute maximum ratings

Parameter	Rating	Comment
Mechanical shock	1 500g/0.5ms half-sine	Any direction. Ref: MIL STD-883G
ESD human body model	±2kV	Ref: JEDEC/ESDA JS-001
Storage temperature	-55°C to +90°C	Up to 1000 hours
VSUP to GND	-0.5 to +7V	
RxD+ or RxD- to GND	-0.3V to +7V	
RxD+ to RxD-	±6V	with 120Ω Line Termination = ON
TxD+ or TxD- to GND	-8V to +8V	
ExtTrig to GND	-0.3V to +7V	
TOV to GND	-0.3V to +7V	
NRST to GND	-0.3V to +7V	
Chassis to GND	500V	
Helium sensitivity		Not to be exposed to helium concentrations higher than those normally found in the atmosphere

6 SPECIFICATIONS

Table 6-1: Operating conditions

Parameter	Conditions	Min	Nom	Max	Unit	Note
INPUT RANGE, ANGULAR RATE			±400		°/s	
INPUT RANGE, ACCELERATION			±10		g	1
INPUT RANGE, INCLINATION			±1.7		g	
POWER SUPPLY		4.5	5.0	5.5	V	2,3
OPERATING TEMPERATURE		-40		+85	°C	

Note 1: Other ranges possible: 5g, 30g and 80g

Note 2: At supply voltages above 5.85V (nominal value) an internal voltage protection circuit will cut power and the unit will go into reset until the voltage is back within operating conditions.

Note 3: At supply voltages below 4.05V (nominal value) the unit will go into reset until the voltage is back within operating conditions. Due to power consumption being much lower in reset compared to normal operation, the series resistance between power source and STIM318 could give rise to an oscillating behaviour of the input voltage to the unit.

Table 6-2: Functional specifications, general

Parameter	Conditions	Min	Nom	Max	Unit	Note
POWER CONSUMPTION						
Power consumption			1.8	2.5	W	
TIMING						
Start-Up time after Power-On				0.3	s	1
Time to transmit after Reset				0.2	s	2
Time to valid data			0.7		s	3
RS422 Bit-Rate			ref. Table 6-7	1	s	3
RS422 Bit-Rate Accuracy				±1	%	4
RS422 PROTOCOL						
Start Bit			1		bit	
Data Length			8		bits	
Parity			None			5
Stop Bits			1		bit	5
RS422 LINE TERMINATION						
Input resistance	Line termination = ON		120		Ω	
Input resistance	Line termination = OFF	48	125		kΩ	
RESET (NRST PIN)						
Logic levels	“high”	2.3			V	
	“low”			0.6	V	
Minimum hold time for reset		1			μs	
Pull-Up Resistor		80	100		kΩ	
EXTERNAL TRIGGER (ExtTrig PIN)						
Logic levels	“high”	2.3			V	
	“low”			0.6	V	
Trigger				Negative transition		
Time between triggers	Measurement unit:					
	angular rate	0.5		127	ms	6,7
	incremental angle	0.5		127	ms	6,8
	average rate	0.5		65	ms	6,9
	integrated angle	0.5		8	ms	6,10
Minimum “high” time before trigger, t_{ext_hi}		250			ns	11
Minimum “low” time after trigger, t_{ext_lo}		250			ns	11
Delay from external trigger to start of transmission, t_{ext_dl}				86	μs	11
Pull-Up Resistor		40	50		kΩ	
Latency				1000	μs	

TIME OF VALIDITY (TOV PIN)				
Output configuration		Open drain		
Internal Pull-Up Resistor to Vsup		10		kΩ
Sink capability			50	mA
TOV active level		Active "low"		
Minimum time of TOV, t_{tov_min}	50			μs
Delay from internal time-tick to TOV active, t_{tov_dl}		1.2	6	μs
Delay from TOV active (to start of transmission), t_{tx_dl}			80	μs
CHASSIS				
Isolation resistance chassis to GND (pin 15)	500V	100		MΩ

Note 1: Time from Power-On to start of datagram transmissions (starting with part-number datagram)

Note 2: Time from Reset release to start of datagram transmissions (starting with part-number datagram)

Note 3: Time from Power-On or Reset to the reset of the Start-Up bit (Bit 6 in the STATUS byte ref. Table 6-18).

During this period the output data should be regarded as non-valid.

Note 4: If a user-defined bit-rate larger than 1.5Mbit/s is used, the deviation may exceed the specification due to the resolution of the bit-rate generator, ref. section 10.5.1

Note 5: Other values can be configured, ref. Table 6-7

Note 6: If time between triggers is longer than 127ms, the sample counter will over-run

Note 7: Time between triggers should be carefully evaluated as long time between triggers in combination with high bandwidths could lead to issues related to folding. Similar for accelerometer and inclinometer outputs

Note 8: If time between triggers is longer than 8ms, an overload may occur in the incremental angle. An overload will be flagged in the status byte, ref. Table 6-18. Similar for accelerometer and inclinometer outputs

Note 9: If time between triggers is longer, the accuracy of average rate may also be reduced. Similar for accelerometer and inclinometer outputs

Note 10: If time between triggers is longer, the integrated angle may have wrapped several times and hence the change in angle from last sample will not be possible to calculate. Similar for accelerometer and inclinometer outputs

Note 11: For definition, ref. Figure 8-3

Note 12: For definition, ref. Figure 8-4 and Figure 8-5

Table 6-3: Functional specifications, gyros

Parameter	Conditions	Min	Nom	Max	Unit	Note
GYRO						
Full Scale (FS)			±400		°/s	1
Resolution			24		bits	
			0.22		°/h	
Scale Factor Accuracy			±500		ppm	
Non-Linearity	±200°/s		15		ppm	2
	±400°/s		20		ppm	2
Bandwidth (-3dB)			262		Hz	3
Sample Rate				2000	samples/s	4
Group Delay	LP-filter -3dB = 262Hz		1.5		ms	5
	LP-filter -3dB = 131Hz		3.0		ms	5
	LP-filter -3dB = 66Hz		6.0		ms	5
	LP-filter -3dB = 33Hz		12		ms	5
	LP-filter -3dB = 16Hz		24		ms	5
Bias Range		-250	0	+250	°/h	
Bias Trim offset range			±1		°/s	
Bias Run-Run			4		°/h	
Drift Rate Stability			3		°/h	
Bias error over temperature	Static temperatures		9		°/h	6
Bias error over temperature gradients	$\Delta T \leq \pm 1^\circ\text{C}/\text{min}$		10		°/h	7
Bias Instability	Allan Variance @25°C		0.3		°/h	
Angular Random Walk	Allan Variance @25°C		0.15		°/√h	

Linear Acceleration Effect Bias	With g-compensation	1	°/h /g	8
	No g-compensation	7	°/h /g	8
Scale Factor	With g-compensation	50	ppm/g	8
	No g-compensation	400	ppm/g	8
Vibration Rectification Coefficient Misalignment		Ref. Figure 6-1	°/h /g ² _{rms}	9
Orthogonality		0.2	mrad	10

Note 1: Output is monotonous and will saturate at $\pm 480^\circ/s$

Note 2: Largest deviation from BSL (Best Straight Line) over the range specified

Note 3: Low-pass filter -3dB frequency can be configured, ref. Table 6-7 and section 6.1.1.4

Note 4: Other values can be configured, ref. Table 6-7. Sample rate will be same for gyros, accelerometers, inclinometers and temperature

Note 5: Total delay to start of datagram transmission = group delay + 0.5ms + t_{tov_dl} + t_{tx_dl} . For output units with delayed output, the group delay will be 1.5ms longer, ref. section 8.4.2.2.1.

Note 6: rms-value calculated on the residuals at static temperatures over the temperature range

Note 7: rms-value calculated on the residual over two temperature-cycles, ref. Figure 6-6

Note 8: Section 7.2 gives advice on sensitive directions

Note 9: Ref. Figure 6-2 for definition of reference points used in axes alignment

Note 10: Gyros, accelerometers and inclinometers are calibrated in the same test-insertion to ensure minimum misalignment between the three sensor-axis systems

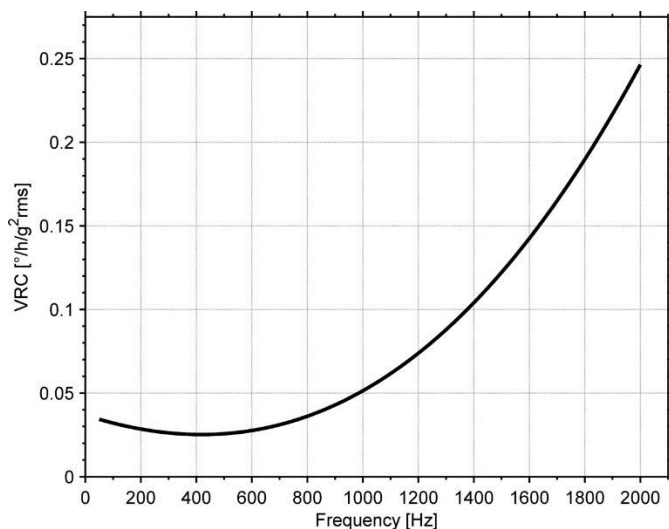

Figure 6-1: Nominal VRC at 20g rms for gyros (ref. section 7.2 for sensitive directions to acceleration-forces)

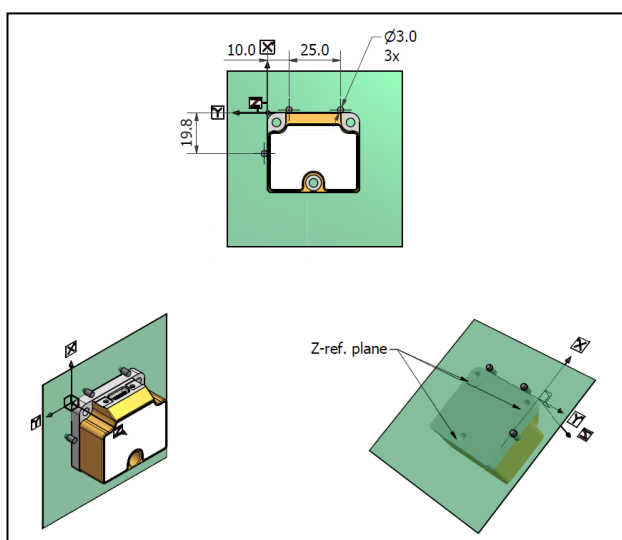

Figure 6-2: Reference points for alignment of axes

Table 6-4: Functional specifications, 10g accelerometers

Parameter	Conditions	Min	Nom	Max	Unit	Note
ACCELEROMETER						
Full Scale (FS)			±10		g	1
Resolution			24		bits	
			1.9		µg	
Scale Factor Accuracy			±200		ppm	
Scale Factor 1 year stability			600		ppm	
Non-Linearity	±10g		100		ppm	2
Bandwidth (-3dB)	LP-filter -3dB = 262Hz		225		Hz	3
Sample Rate				2000	samples/s	4
Group Delay	LP-filter -3dB = 262Hz		3.0		ms	5
	LP-filter -3dB = 131Hz		4.5		ms	5
	LP-filter -3dB = 66Hz		7.5		ms	5
	LP-filter -3dB = 33Hz		13		ms	5
	LP-filter -3dB = 16Hz		25		ms	5
Bias 1 year stability, STIM318		1.25	1.5		mg	
Bias 1 year stability, STIM318e			1.2		mg	6
Bias Trim offset range	$\Delta T \leq \pm 1^\circ\text{C}/\text{min}$		±100		mg	
Bias error over temperature			±0.7		mg rms	
Bias Instability	Allan Variance @25°C		0.003		mg	
Velocity Random Walk	Allan Variance @25°C		0.015		m/s/√h	
Vibration Rectification Coefficient			Ref. Figure 6-3		mg/g ² _{rms}	
Misalignment			1		mrad	7
Orthogonality			0.2		mrad	8

Note 1: Overload-bit in STATUS-byte (ref. section 6.4) will be set at 11g (+10% of range)

Note 2: Largest deviation from BSL (Best Straight Line) over the range specified

Note 3: Other values can be configured, ref. Table 6-7 and section 6.1.2.3

Note 4: Other values can be configured, ref. Table 6-7. Sample rate will be same for gyros, accelerometers, inclinometers and temperature

Note 5: Total delay to start of datagram transmission = group delay + 0.5ms + $t_{\text{tov_dl}}$ + $t_{\text{tx_dl}}$

Note 6: STIM318e will require export-license

Note 7: Ref. Figure 6-2 for definition of reference points used in axes alignment

Note 8: Gyros, accelerometers and inclinometers are calibrated in the same test-insertion to ensure minimum misalignment between the three sensor-axis systems

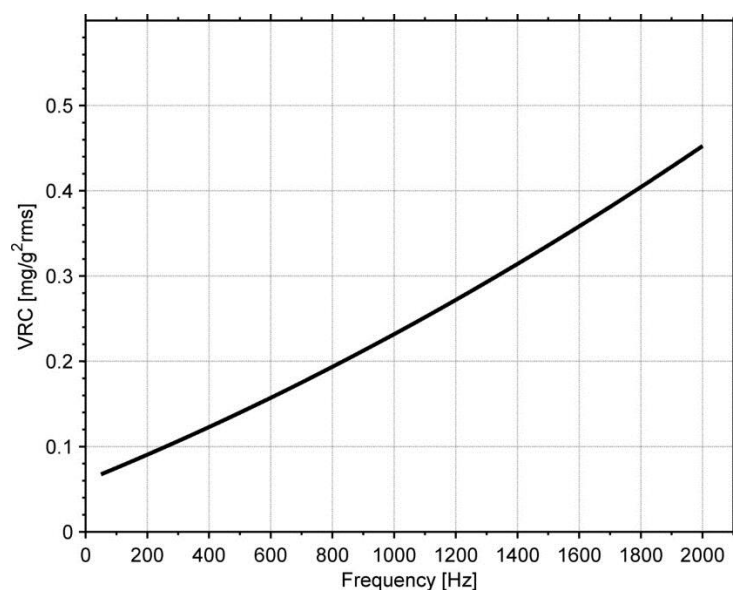

Figure 6-3: Nominal VRC at 10g rms for 10g accelerometers

Table 6-5: Functional specifications, inclinometers

Parameter	Conditions	Min	Nom	Max	Unit	Note
INCLINOMETER						
Full Scale (FS)			±1.7		g	1
Resolution			24		bits	
Scale Factor Accuracy	±1g		0.2		µg	
Non-Linearity	±1g		±500		ppm	2
Bandwidth (-3dB)			250		ppm	3
Sample Rate			17	2000	Hz	4
Group Delay	LP-filter -3dB = 262Hz		11		samples/s	5
	LP-filter -3dB = 131Hz		14		ms	5
	LP-filter -3dB = 66Hz		16		ms	5
	LP-filter -3dB = 33Hz		22		ms	5
	LP-filter -3dB = 16Hz		34		ms	5
Bias trim offset range			±20		mg	
Bias error over temperature	ΔT ≤ ±1°C/min		±2		mg rms	
Bias Instability	Allan Variance @25°C		0.05		mg	6
Velocity Random Walk	Allan Variance @25°C		0.08		m/s/√h	6
Misalignment			1		mrad	7
Orthogonality			0.2		mrad	8

Note 1: Overload-bit in STATUS-byte (ref. section 6.4) will be set at ±1.87g (+10% of range)

Note 2: Largest deviation from BSL (Best Straight Line) over the range specified

Note 3: Other values can be configured, ref. Table 6-7 and section 6.1.3.3

Note 4: Other values can be configured, ref. Table 6-7. Sample rate will be same for gyros, accelerometers, inclinometers and temperature

Note 5: Total delay to start of datagram transmission = group delay + 0.5ms + t_{tov_dl} + t_{bx_dl}

Note 6: At 0g. Bias Instability and Velocity Random Walk increases by typically 35% at ±1g given by the chosen technology for the inclinometers

Note 7: Ref. Figure 6-2 for definition of reference points used in axes alignment

Note 8: Gyros, accelerometers and inclinometers are calibrated in the same test-insertion to ensure minimum misalignment between the three sensor-axis systems

Table 6-6: Functional specifications, temperature

Parameter	Conditions	Min	Nom	Max	Unit	Note
Resolution			0.0039		°C	
Bias Accuracy	@25°C		±5		°C	1
Scale factor accuracy			±5		%	
Sample Rate				2000	samples/s	2

Note 1: Temperature measured at gyros. Temperature calibrated at static condition and referred to ambient temperature

Note 2: Other values can be configured, ref. Table 6-7. Sample rate will be same for gyros, accelerometers, inclinometers and temperature

6.1 TYPICAL PERFORMANCE CHARACTERISTICS

6.1.1 GYRO CHARACTERISTICS

6.1.1.1 Root Allan Variance of gyro

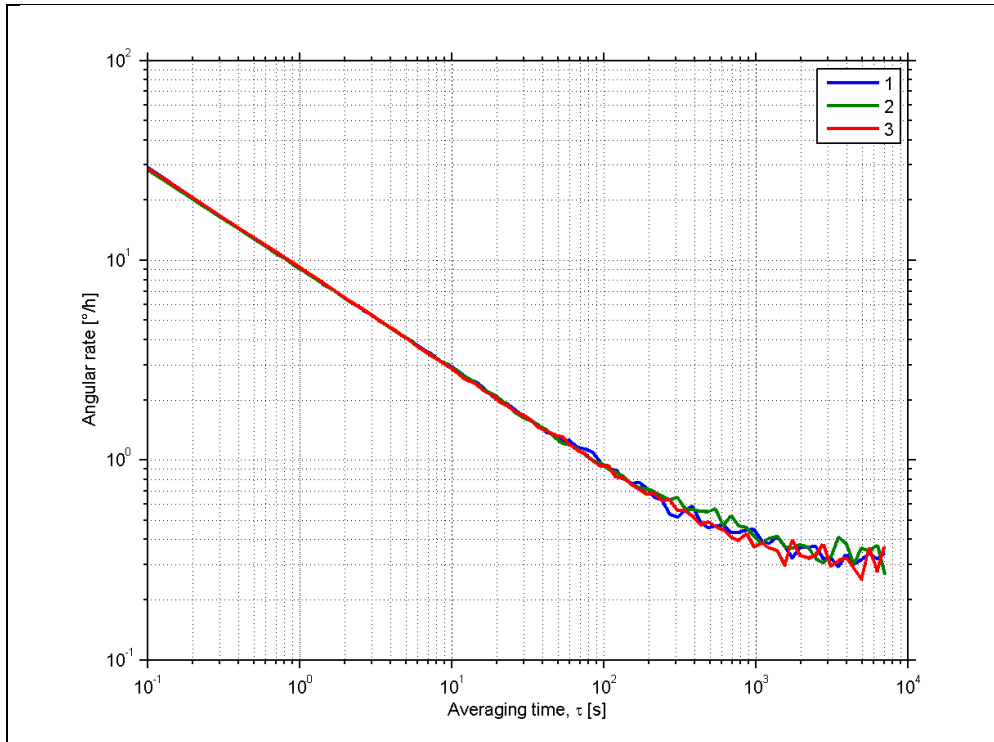

Figure 6-4: Typical Root Allan-Variance of gyro (400°/s gyro)

6.1.1.2 Initial bias drift of gyro

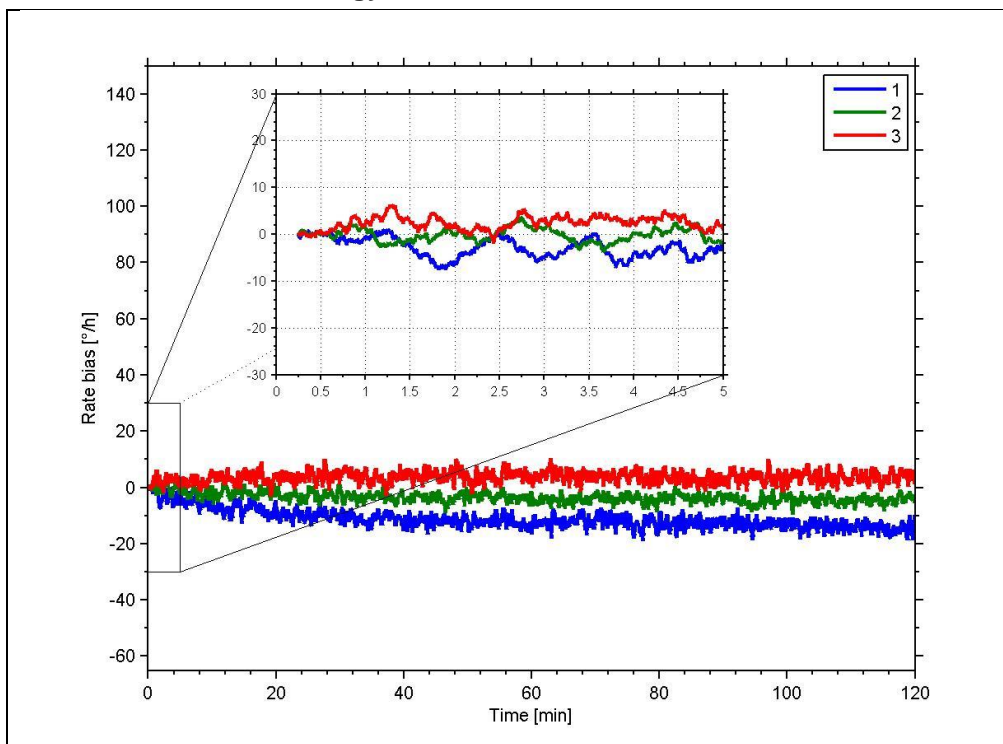

Figure 6-5: Typical normalized initial bias drift of gyro (400°/s gyro)

6.1.1.3 Bias drift over temperature

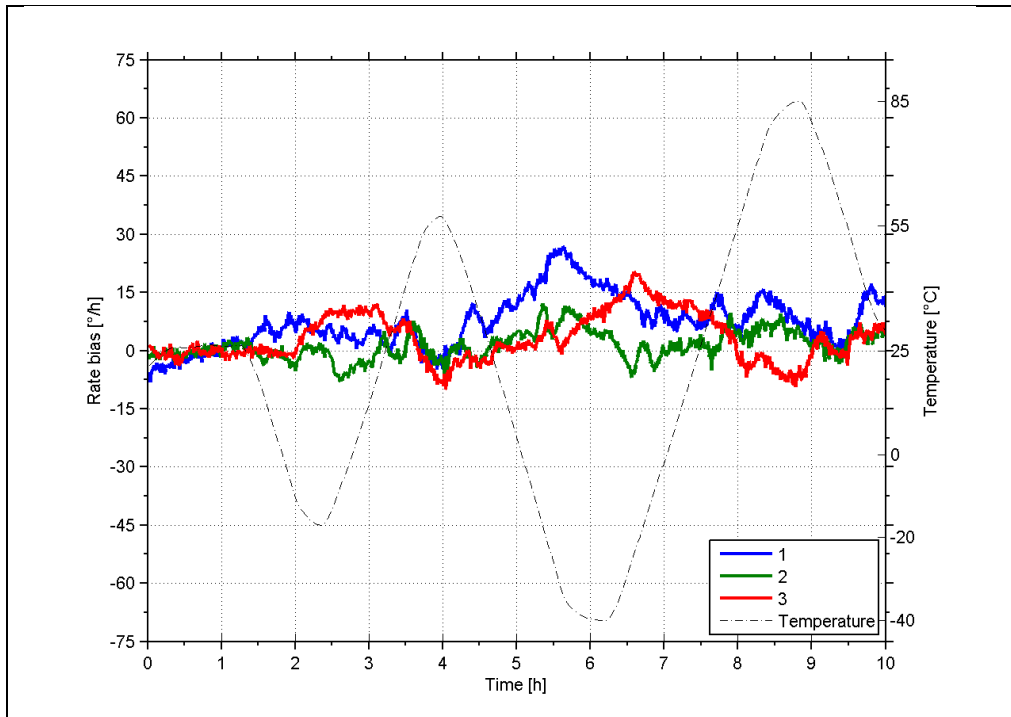

Figure 6-6: Typical Bias drift over temperature (400°/s gyro)

6.1.1.4 Frequency characteristics of gyros

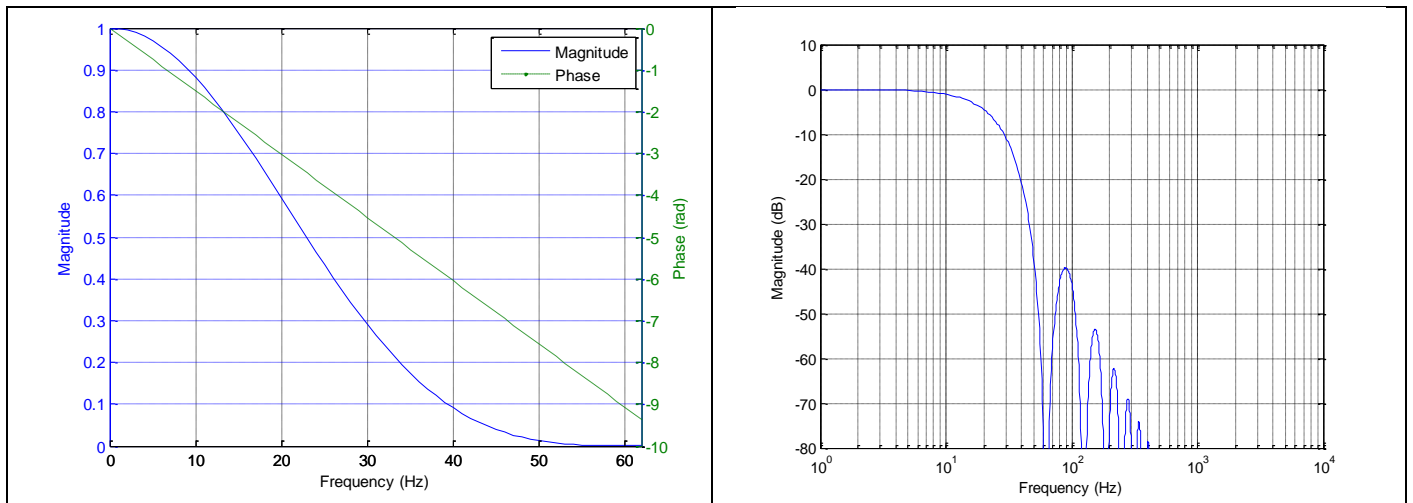

Figure 6-7: Frequency characteristics of gyros with low-pass filter -3dB frequency set to 16Hz

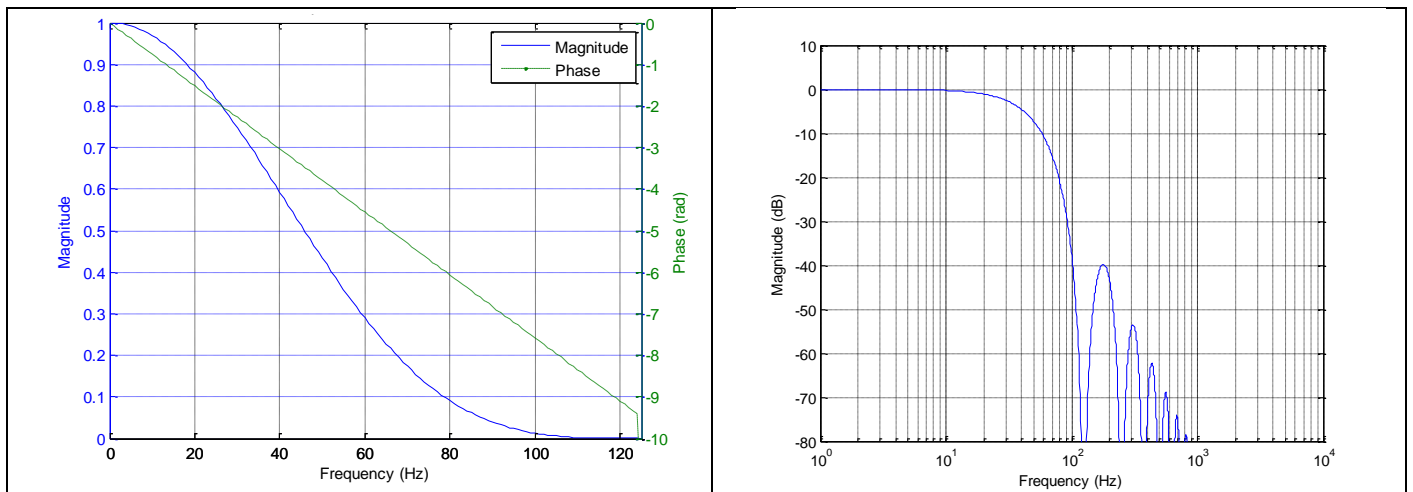

Figure 6-8: Frequency characteristics of gyros with low-pass filter -3dB frequency set to 33Hz

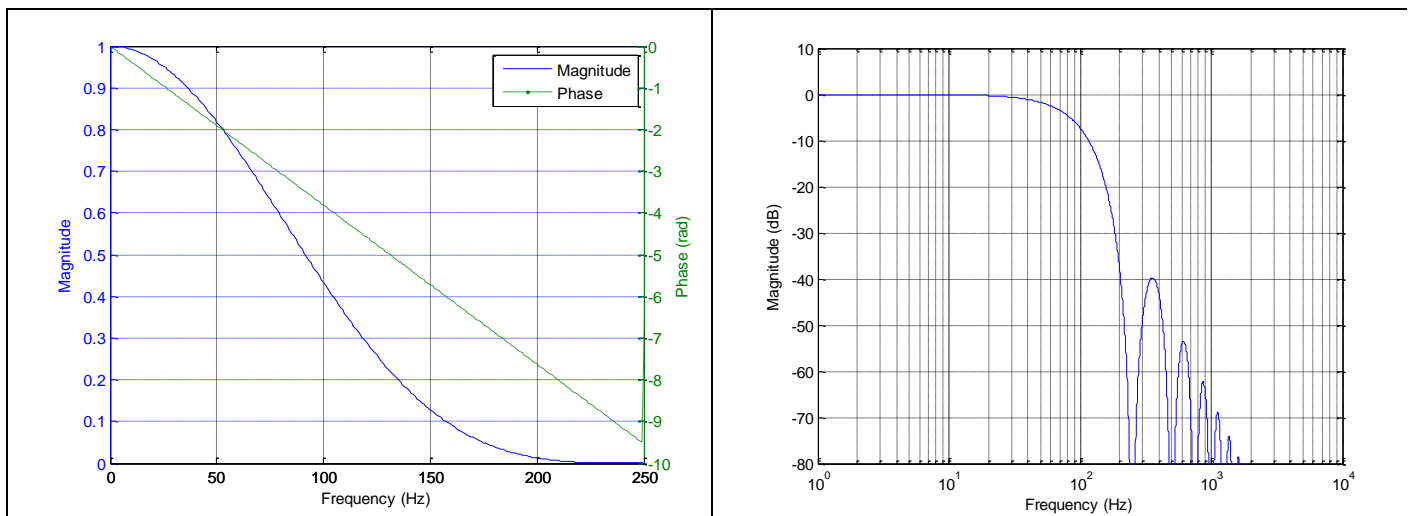

Figure 6-9: Frequency characteristics of gyros with low-pass filter -3dB frequency set to 66Hz

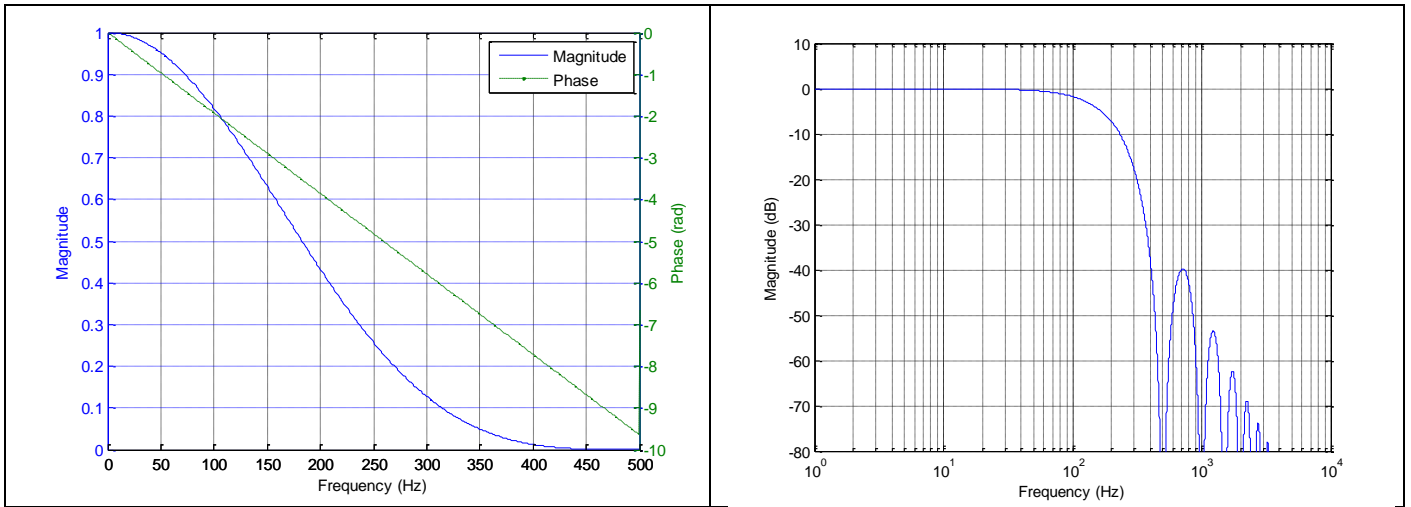

Figure 6-10: Frequency characteristics of gyros with low-pass filter -3dB frequency set to 131Hz

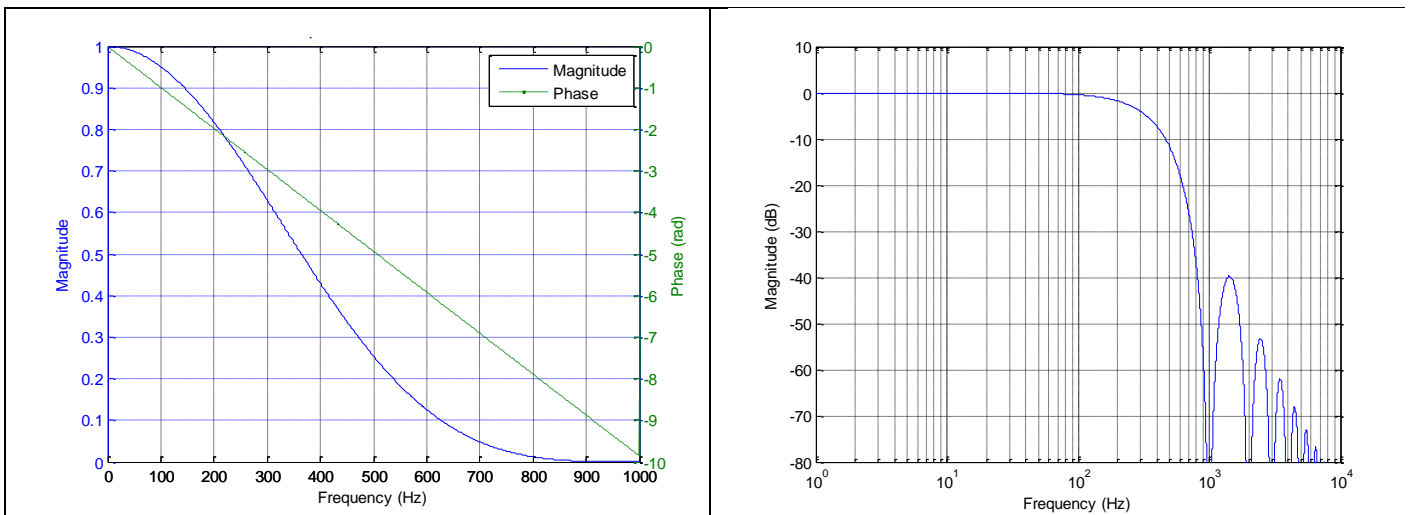

Figure 6-11: Frequency characteristics of gyros with low-pass filter -3dB frequency set to 262Hz

6.1.2 ACCELEROMETER CHARACTERISTICS

6.1.2.1 Root Allan Variance of accelerometer

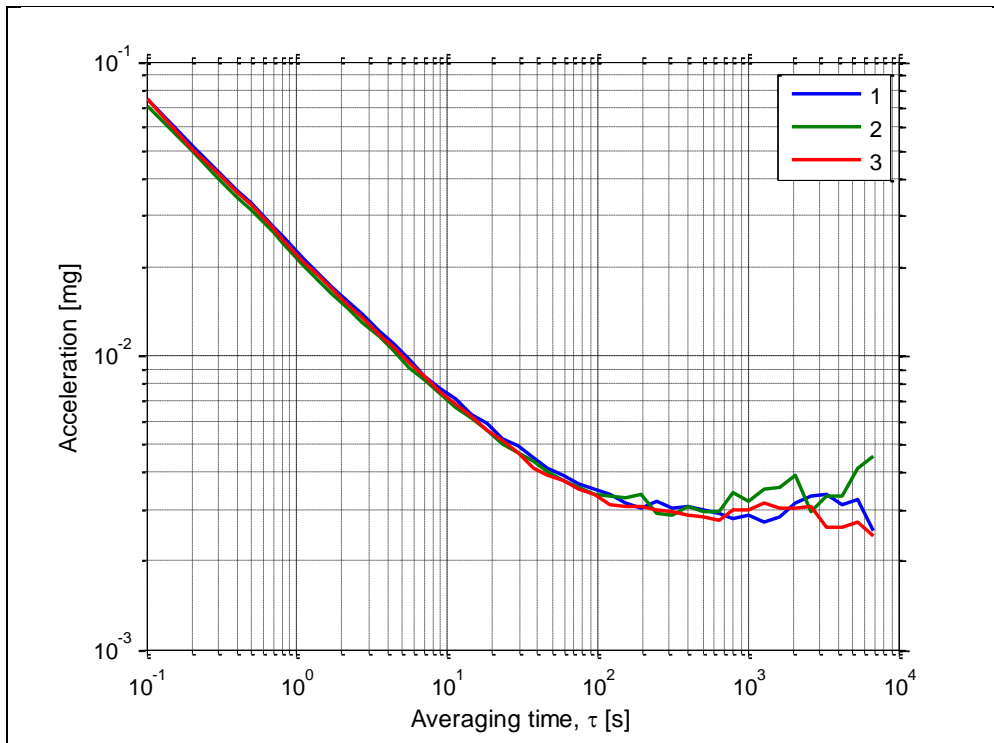

Figure 6-12: Typical Allan-Variance of accelerometer (10g accelerometer)

6.1.2.2 Initial bias drift of accelerometer

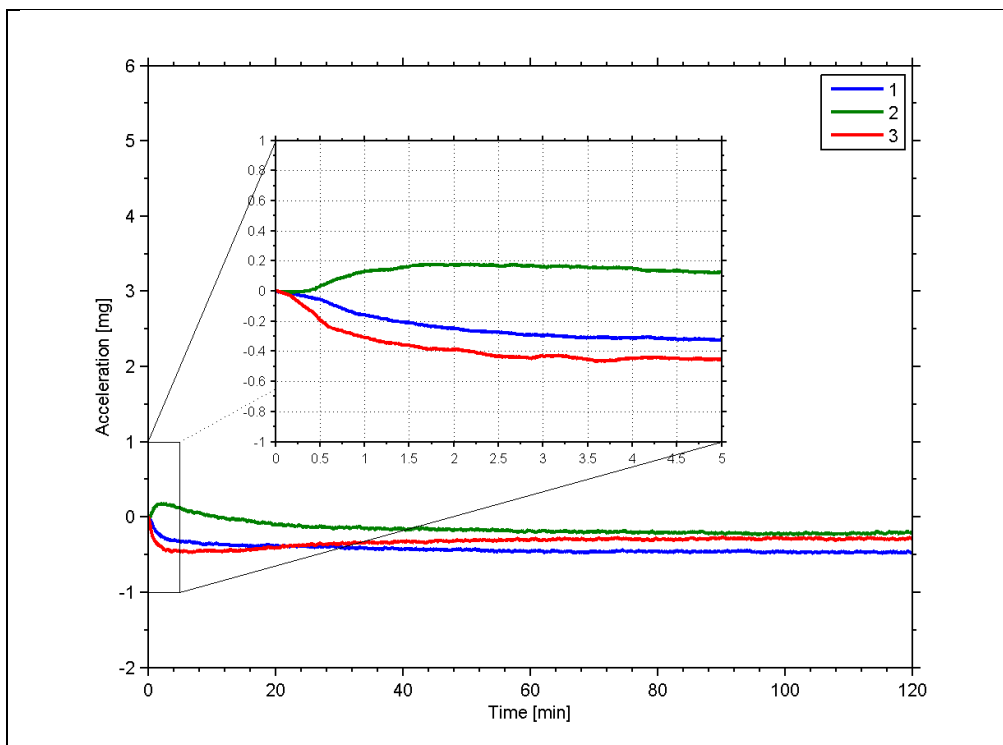

Figure 6-13: Typical normalized initial bias drift of accelerometer (10g accelerometer)

6.1.2.3 Frequency characteristics of accelerometers

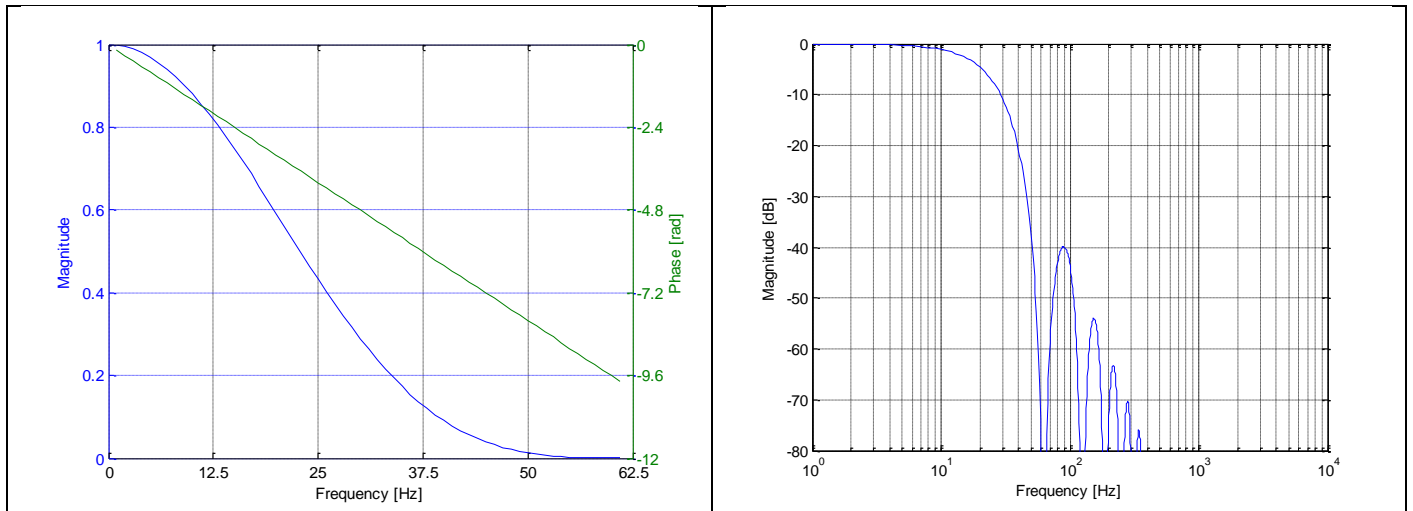

Figure 6-14: Frequency characteristics of accelerometers with low-pass filter -3dB frequency set to 16Hz

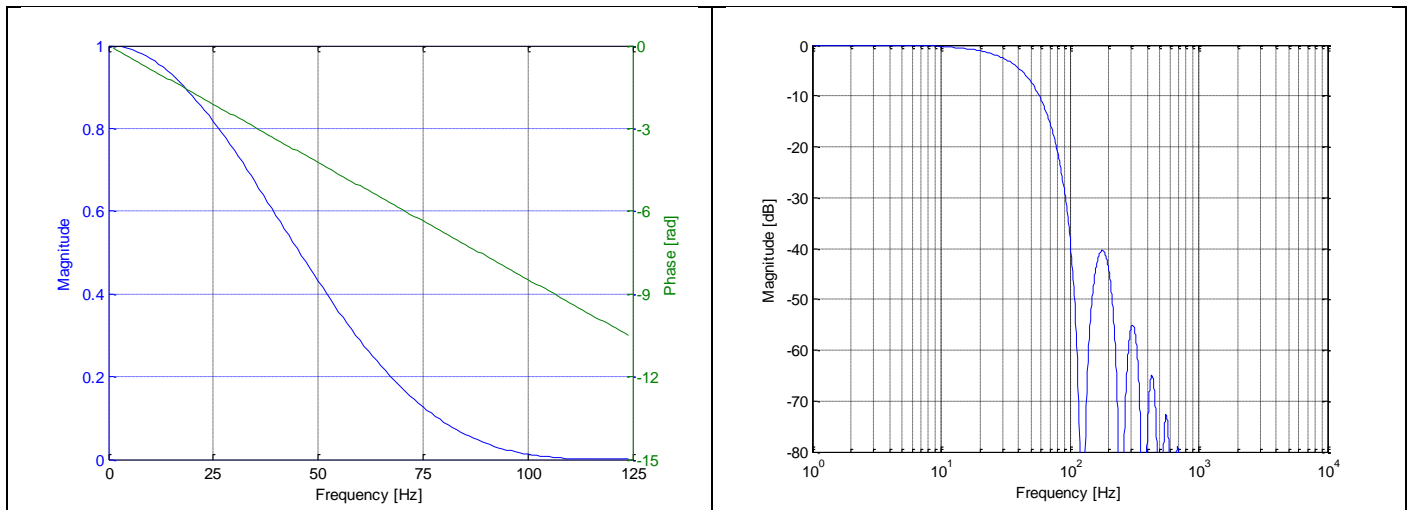

Figure 6-15: Frequency characteristics of accelerometers with low-pass filter -3dB frequency set to 33Hz

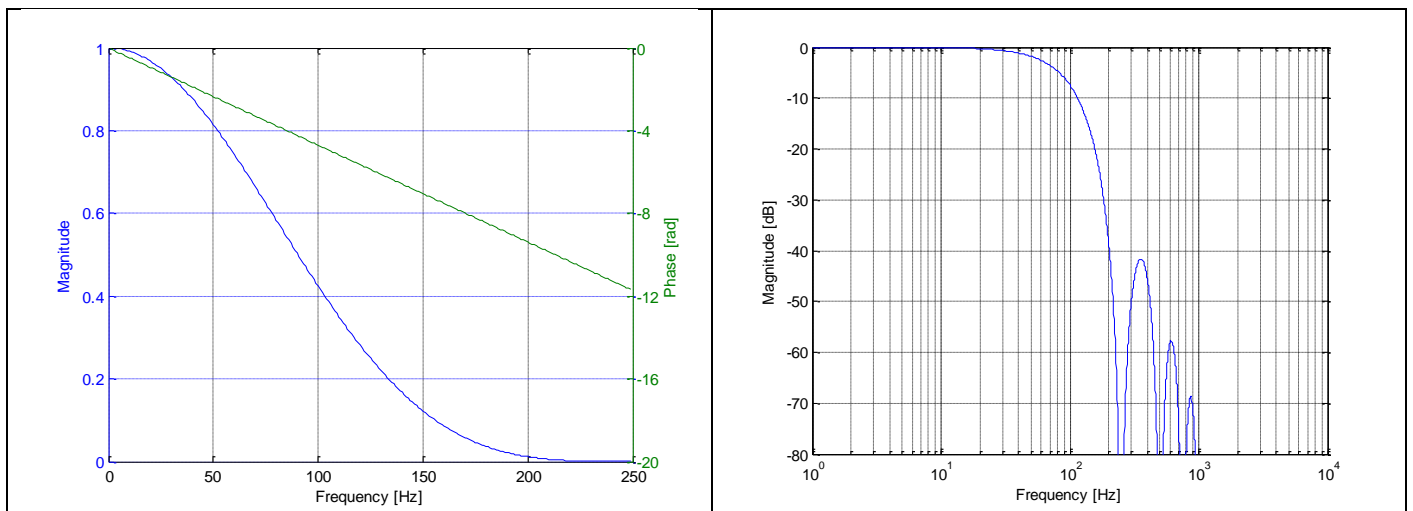

Figure 6-16: Frequency characteristics of accelerometers with low-pass filter -3dB frequency set to 66Hz

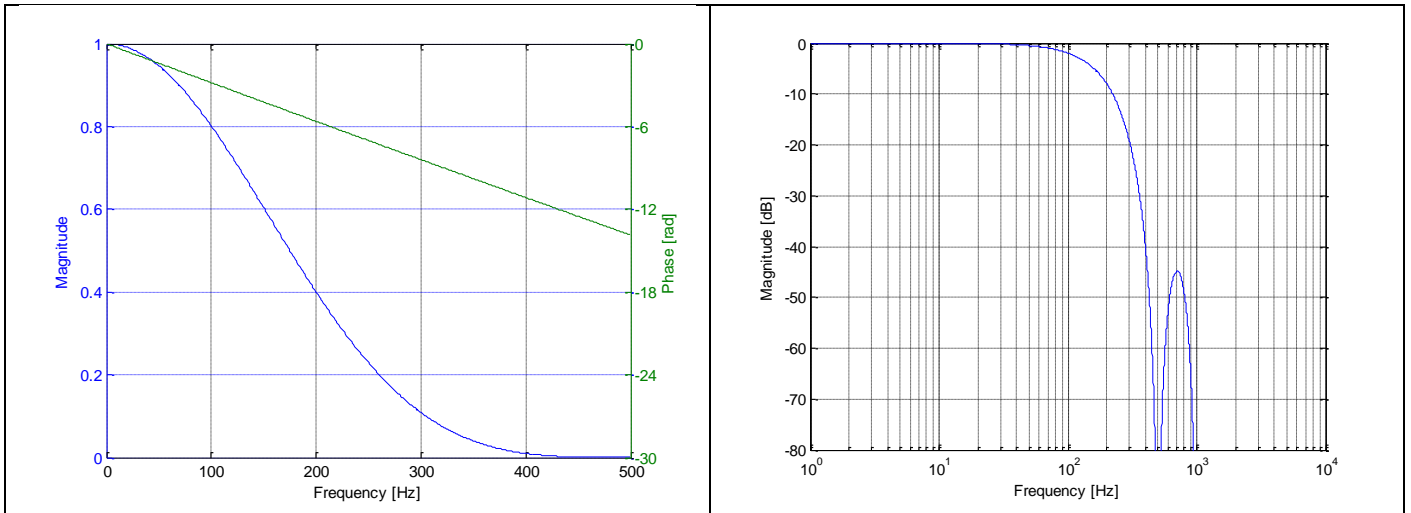

Figure 6-17: Frequency characteristics of accelerometers with low-pass filter -3dB frequency set to 131Hz

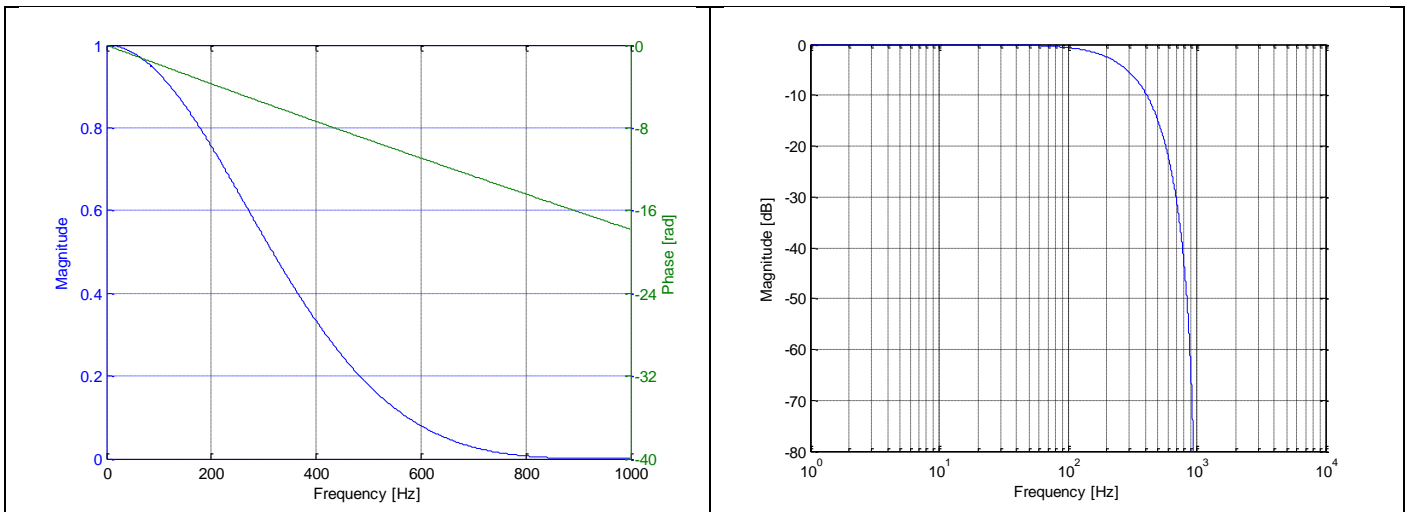

Figure 6-18: Frequency characteristics of accelerometers with low-pass filter -3dB frequency set to 262Hz

6.1.3 INCLINOMETER CHARACTERISTICS

6.1.3.1 Root Allan Variance of inclinometer

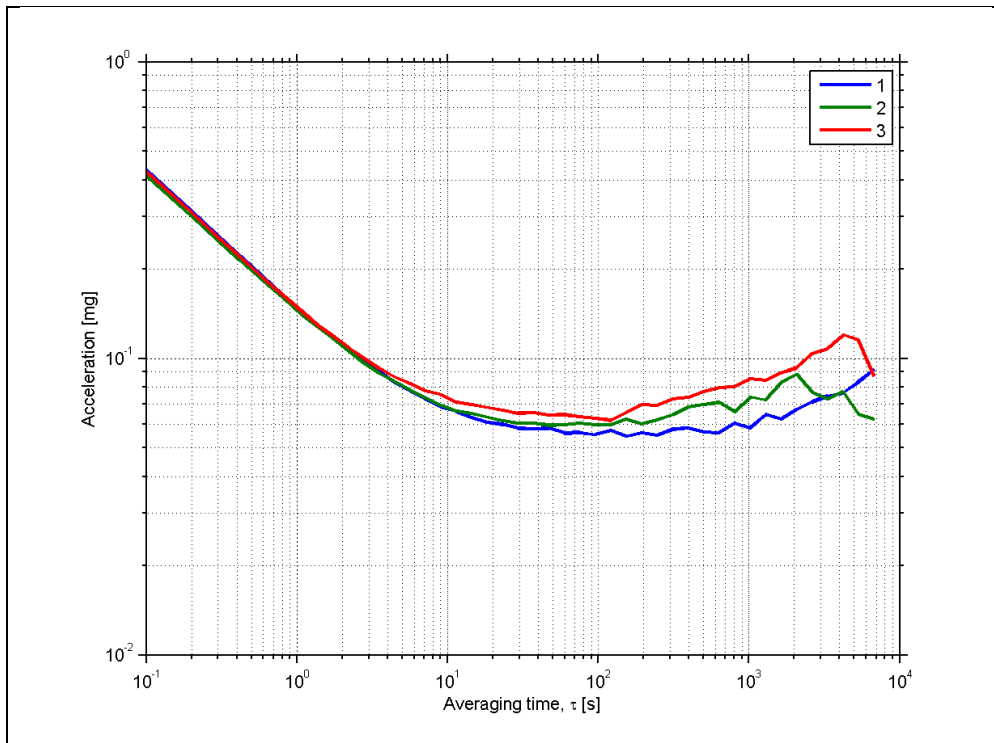

Figure 6-19: Typical Allan-Variance of inclinometer

6.1.3.2 Initial bias drift of inclinometer

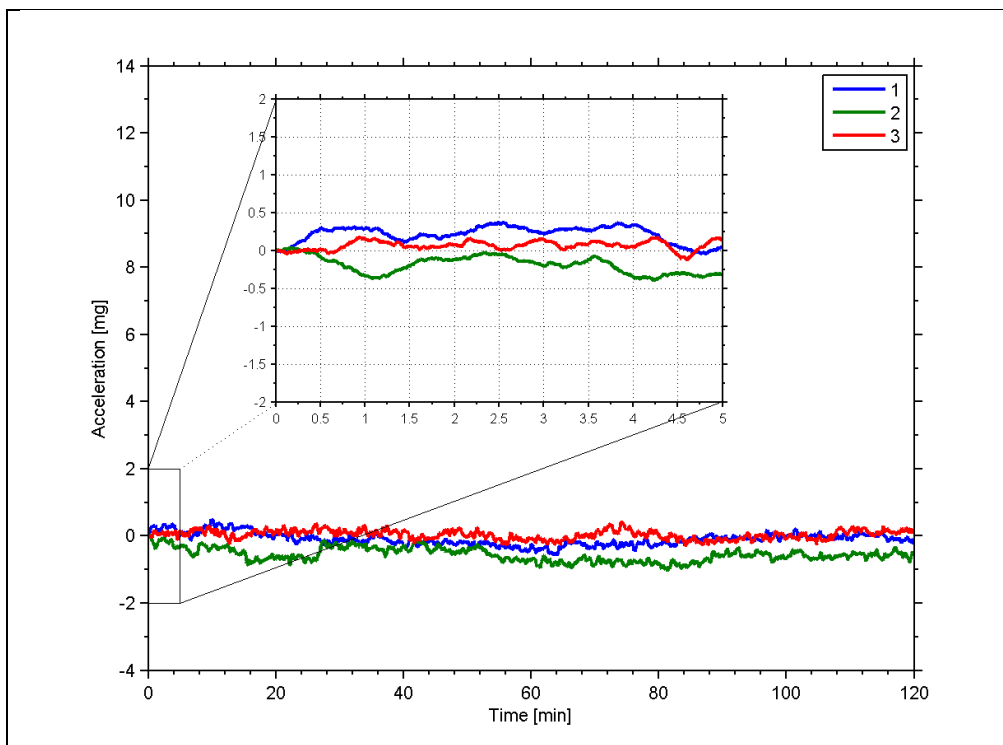

Figure 6-20: Typical normalized initial bias drift of inclinometer

6.1.3.3 Frequency characteristics of inclinometers

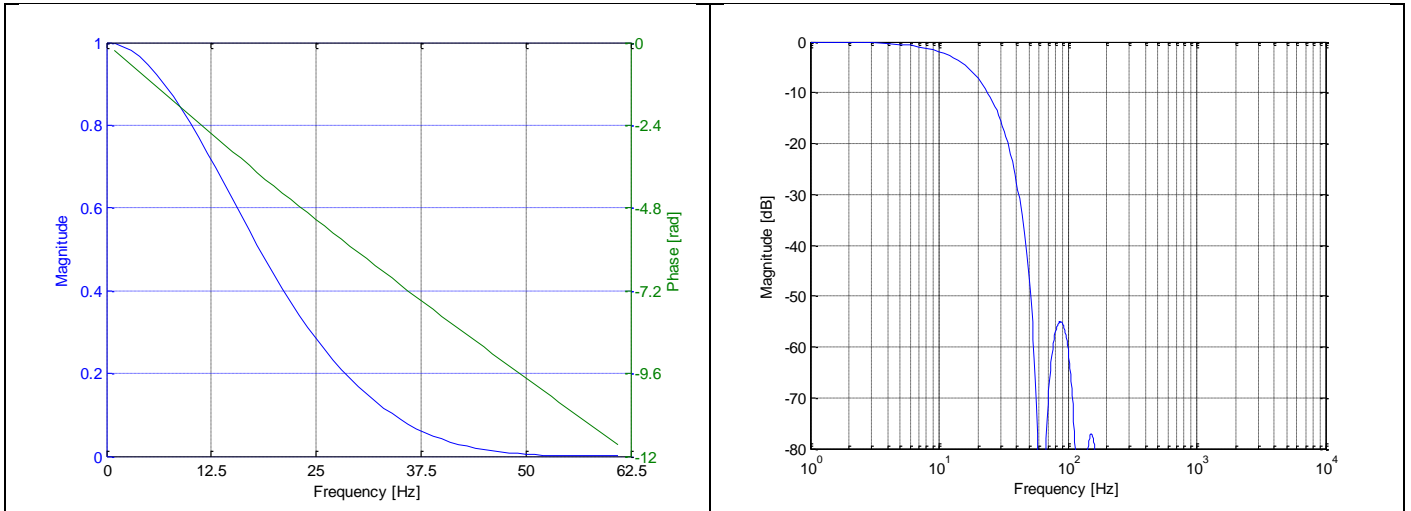

Figure 6-21: Frequency characteristics of inclinometers with low-pass filter -3dB frequency set to 16Hz

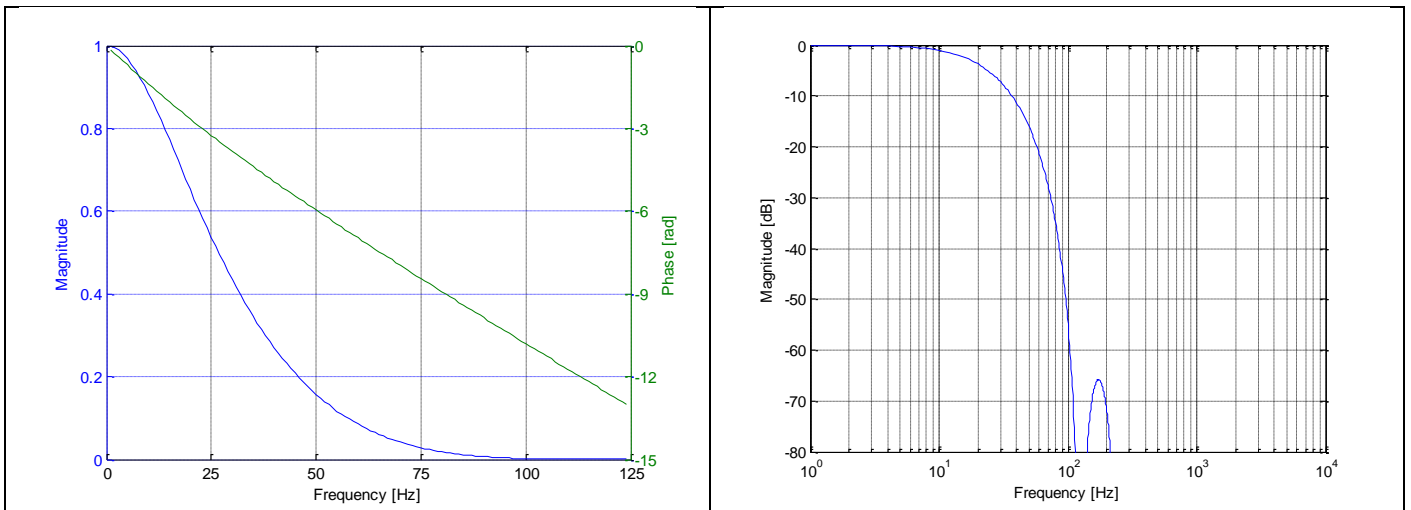

Figure 6-22: Frequency characteristics of inclinometers with low-pass filter -3dB frequency set to 33Hz

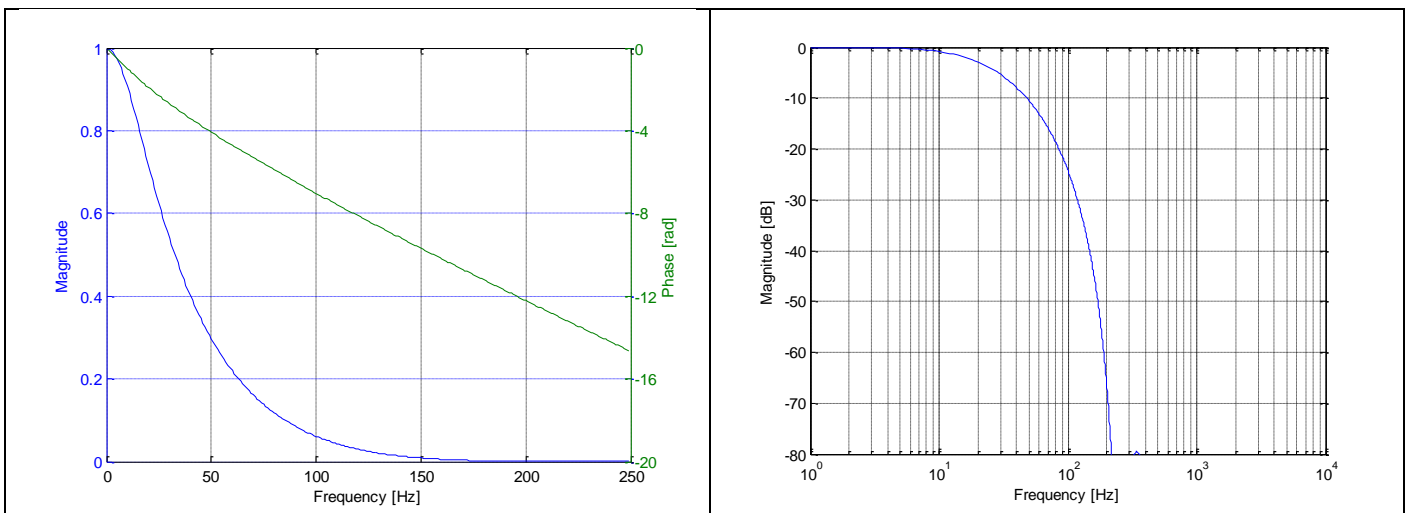

Figure 6-23: Frequency characteristics of inclinometers with low-pass filter -3dB frequency set to 66Hz

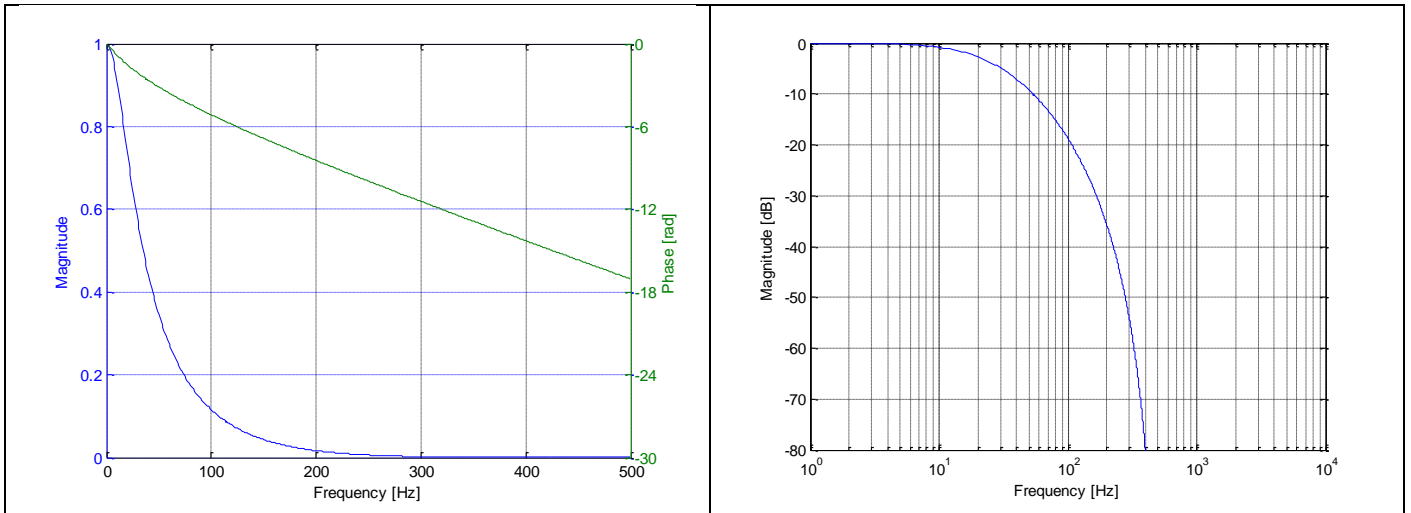

Figure 6-24: Frequency characteristics of inclinometers with low-pass filter -3dB frequency set to 131Hz

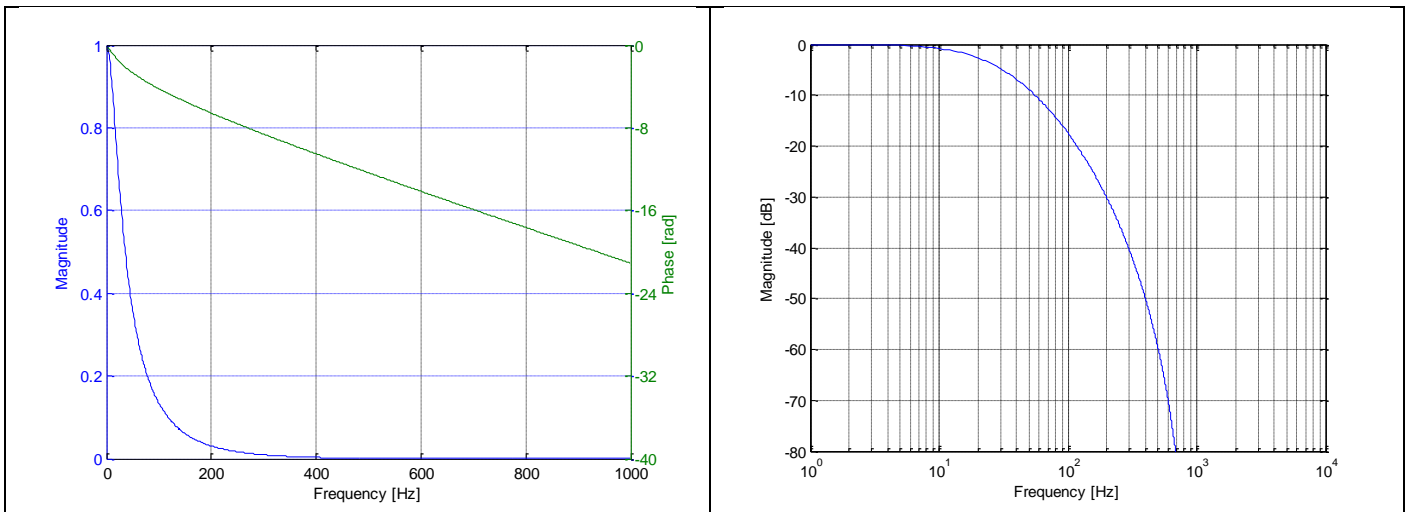

Figure 6-25: Frequency characteristics of inclinometers with low-pass filter -3dB frequency set to 262Hz

6.2 Configurable parameters

Table 6-7: Configurable parameters

Parameter	Configurations	Comments
SAMPLE RATE	125 samples/s 250 samples/s 500 samples/s 1000 samples/s 2000 samples/s External trigger	Some limitations apply to the use of higher sample rates (>500 samples/s), dependent on selected bit-rate and datagram content, ref. Table 6-8
LOW-PASS FILTER -3dB FREQUENCY	16Hz 33Hz 66Hz 131Hz 262Hz	Filter settings are independent of sample rate. Low-pass filters are CIC type filters with linear phase response. Filter settings can be set individually for each axis.
MEASUREMENT UNIT GYRO	Angular rate [°/s] Incremental angle [°/sample] Average angular rate [°/s] Integrated angle [°]	
MEASUREMENT UNIT ACCELEROMETER	Acceleration [g] Incremental velocity [m/s/sample] Average acceleration [g] Integrated velocity [m/s]	
MEASUREMENT UNIT INCLINOMETER	Acceleration [g] Incremental velocity [m/s/sample] Average acceleration [g] Integrated velocity [m/s]	
DATAGRAM	Rate together with any combination of acceleration, inclination and temperature	
DATAGRAM TERMINATION	NONE <CR><LF>	
RS422 BIT-RATE	374400 bits/s 460800 bits/s 921600 bits/s 1843200 bits/s User-defined	Some limitations apply to the use of lower bit-rates (< 1843200 bits/s) dependent on sample rate and datagram content, ref. Table 6-8. For user-defined bit-rates, see section 10.5
RS422 PARITY	None Odd Even	
RS422 STOP BITS	1 stop bit 2 stop bits	
RS422 120Ω LINE TERMINATION	OFF ON	

Refer to section 13 for information on how to configure STIM318 when ordering and to section 10 for information on how to reconfigure the unit in Service Mode.

Some datagrams are longer than the time between each sample at the lower bit-rate. Table 6-8 shows the maximum bit-rates.

Table 6-8: Maximum sample rate

Datagram content	Number of transmitted bytes ^{Note 1}	374400 bits/s ^{Note 2}	460800 bits/s ^{Note 2}	921600 bits/s ^{Note 2}	1843200 bits/s ^{Note 2}
Rate	18	1000	2000	2000	2000
Rate and acceleration	28	1000	1000	2000	2000
Rate and inclination	28	1000	1000	2000	2000
Rate, acceleration and inclination	38	500	1000	2000	2000
Rate and temperature	25	1000	1000	2000	2000
Rate, acceleration and temperature	42	500	500	1000	2000
Rate, inclination and temperature	42	500	500	1000	2000
Rate, acceleration, inclination and temperature	59	500	500	1000	2000

Note 1: excluding <CR><LF> termination

Note 2: 10 bits/byte (=1 start bit, 8 data bits, no parity bit, 1 stop bit)

6.3 Datagram specifications

6.3.1 Part Number datagram

Table 6-9: Specification of the Part Number datagram

Byte#	Bit#								Specification
	7	6	5	4	3	2	1	0	
0	1	0	1	1	0	0	0	1	Part Number datagram identifier: 0xB1 for datagrams without CR+LF termination 0xB3 for datagrams with CR+LF termination
1	0	0	0	0	P ₁₃	P ₁₂	P ₁₁	P ₁₀	Low nibble: 1.digit of part number
2	P ₂₃	P ₂₂	P ₂₁	P ₂₀	P ₃₃	P ₃₂	P ₃₁	P ₃₀	High nibble: 2.digit of part number Low nibble: 3.digit of part number
3	P ₄₃	P ₄₂	P ₄₁	P ₄₀	P ₅₃	P ₅₂	P ₅₁	P ₅₀	High nibble: 4.digit of part number Low nibble: 5.digit of part number
4	0	0	1	0	1	1	0	1	ASCII character "-" (0x2D)
5	P ₆₃	P ₆₂	P ₆₁	P ₆₀	P ₇₃	P ₇₂	P ₇₁	P ₇₀	High nibble: 6.digit of part number Low nibble: 7.digit of part number
6	P ₈₃	P ₈₂	P ₈₁	P ₈₀	P ₉₃	P ₉₂	P ₉₁	P ₉₀	High nibble: 8.digit of part number Low nibble: 9.digit of part number
7	P ₁₀₃	P ₁₀₂	P ₁₀₁	P ₁₀₀	P ₁₁₃	P ₁₁₂	P ₁₁₁	P ₁₁₀	High nibble: 10.digit of part number Low nibble: 11.digit of part number
8	0	0	1	0	1	1	0	1	ASCII character "-" (0x2D)
9	P ₁₂₃	P ₁₂₂	P ₁₂₁	P ₁₂₀	P ₁₃₃	P ₁₃₂	P ₁₃₁	P ₁₃₀	High nibble: 12.digit of part number Low nibble: 13.digit of part number
10	P ₁₄₃	P ₁₄₂	P ₁₄₁	P ₁₄₀	x	x	x	x	High nibble: 14.digit of part number
11	x	x	x	x	x	x	x	x	For future use
12	x	x	x	x	x	x	x	x	For future use
13	x	x	x	x	x	x	x	x	For future use
14	x	x	x	x	x	x	x	x	For future use
15	r ₇	r ₆	r ₅	r ₄	r ₃	r ₂	r ₁	r ₀	Part number revision. Content of byte represents the ASCII-character of the revision. Numbering sequence: "-", "A", "B", ..., "Z"
16	C ₃₁	C ₃₀	C ₂₉	C ₂₈	C ₂₇	C ₂₆	C ₂₅	C ₂₄	Cyclic Redundancy Check is performed on all preceding bytes, ref. section 6.3.7
17	C ₂₃	C ₂₂	C ₂₁	C ₂₀	C ₁₉	C ₁₈	C ₁₇	C ₁₆	
18	C ₁₅	C ₁₄	C ₁₃	C ₁₂	C ₁₁	C ₁₀	C ₉	C ₈	
19	C ₇	C ₆	C ₅	C ₄	C ₃	C ₂	C ₁	C ₀	
(20)	0	0	0	0	1	1	0	1	<CR> If datagram termination has been selected
(21)	0	0	0	0	1	0	1	0	<LF> If datagram termination has been selected

6.3.2 Serial Number datagram

Table 6-10: Specification of the Serial Number datagram

Byte#	Bit#								Specification
	7	6	5	4	3	2	1	0	
0	1	0	1	1	0	1	0	1	Serial Number datagram identifier: 0xB5 for datagrams without CR+LF termination 0xB7 for datagrams with CR+LF termination
1	0	1	0	0	1	1	1	0	ASCII-character for letter "N"
2	S ₁₃	S ₁₂	S ₁₁	S ₁₀	S ₂₃	S ₂₂	S ₂₁	S ₂₀	High nibble: 1.digit (BCD) of serial number Low nibble: 2.digit (BCD) of serial number
3	S ₃₃	S ₃₂	S ₃₁	S ₃₀	S ₄₃	S ₄₂	S ₄₁	S ₄₀	High nibble: 3.digit (BCD) of serial number Low nibble: 4.digit (BCD) of serial number
4	S ₅₃	S ₅₂	S ₅₁	S ₅₀	S ₆₃	S ₆₂	S ₆₁	S ₆₀	High nibble: 5.digit (BCD) of serial number Low nibble: 6.digit (BCD) of serial number
5	S ₇₃	S ₇₂	S ₇₁	S ₇₀	S ₈₃	S ₈₂	S ₈₁	S ₈₀	High nibble: 7.digit (BCD) of serial number Low nibble: 8.digit (BCD) of serial number
6	S ₉₃	S ₉₂	S ₉₁	S ₉₀	S ₁₀₃	S ₁₀₂	S ₁₀₁	S ₁₀₀	High nibble: 9.digit (BCD) of serial number Low nibble: 10.digit (BCD) of serial number
7	S ₁₁₃	S ₁₁₂	S ₁₁₁	S ₁₁₀	S ₁₁₃	S ₁₁₂	S ₁₁₁	S ₁₁₀	High nibble: 11.digit (BCD) of serial number Low nibble: 12.digit (BCD) of serial number
8	S ₁₃₃	S ₁₃₂	S ₁₃₁	S ₁₃₀	S ₁₄₃	S ₁₄₂	S ₁₄₁	S ₁₄₀	High nibble: 13.digit (BCD) of serial number Low nibble: 14.digit (BCD) of serial number
9	x	x	x	x	x	x	x	x	For future use
10	x	x	x	x	x	x	x	x	For future use
11	x	x	x	x	x	x	x	x	For future use
12	x	x	x	x	x	x	x	x	For future use
13	x	x	x	x	x	x	x	x	For future use
14	x	x	x	x	x	x	x	x	For future use
15	x	x	x	x	x	x	x	x	For future use
16	C ₃₁	C ₃₀	C ₂₉	C ₂₈	C ₂₇	C ₂₆	C ₂₅	C ₂₄	Cyclic Redundancy Check is performed on all preceding bytes, ref. section 6.3.7
17	C ₂₃	C ₂₂	C ₂₁	C ₂₀	C ₁₉	C ₁₈	C ₁₇	C ₁₆	
18	C ₁₅	C ₁₄	C ₁₃	C ₁₂	C ₁₁	C ₁₀	C ₉	C ₈	
19	C ₇	C ₆	C ₅	C ₄	C ₃	C ₂	C ₁	C ₀	
(20)	0	0	0	0	1	1	0	1	<CR> If datagram termination has been selected
(21)	0	0	0	0	1	0	1	0	<LF> If datagram termination has been selected

6.3.3 Configuration datagram

Table 6-11: Specification of the Configuration datagram

Byte#	Bit#								Specification
	7	6	5	4	3	2	1	0	
0	1 1	0 0	1 1	1 1	1 1	1 1	0 0	0 1	Configuration datagram identifier: 0xBC for datagrams without CR+LF termination 0xBD for datagrams with CR+LF termination
1	r ₇	r ₆	r ₅	r ₄	r ₃	r ₂	r ₁	r ₀	Part number revision. Content of byte represents the ASCII-character of the revision. Numbering sequence: “-”, “A”, “B”, ..., “Z”
2	f ₇	f ₆	f ₅	f ₄	f ₃	f ₂	f ₁	f ₀	Firmware revision. Numbering sequence: 0, 1, ..., 255
3	0	0	0	x	x	x	x	x	System configuration, Byte 1: Sample frequency = 125 samples/s
	0	0	1	x	x	x	x	x	Sample frequency = 250 samples/s
	0	1	0	x	x	x	x	x	Sample frequency = 500 samples/s
	0	1	1	x	x	x	x	x	Sample frequency = 1000 samples/s
	1	0	0	x	x	x	x	x	Sample frequency = 2000 samples/s
	1	0	1	x	x	x	x	x	Sample frequency = External trigger
	x	x	x	x	0	x	x	x	Temperature not included in Normal Mode datagram
	x	x	x	x	1	x	x	x	Temperature included in Normal Mode datagram
	x	x	x	x	x	0	x	x	Inclination not included in Normal Mode datagram
	x	x	x	x	x	1	x	x	Inclination included in Normal Mode datagram
	x	x	x	x	x	x	0	x	Acceleration not included in Normal Mode datagram
x	x	x	x	x	x	1	x	Acceleration included in Normal Mode datagram	
x	x	x	x	x	x	x	0	No <CR><LF> termination of Normal Mode datagram	
x	x	x	x	x	x	x	1	<CR><LF> termination of Normal Mode datagram	
4	0	0	0	0	x	x	x	x	System configuration, Byte 2: Bit-rate = 374400 bits/s
	0	0	0	1	x	x	x	x	Bit-rate = 460800 bits/s
	0	0	1	0	x	x	x	x	Bit-rate = 921600 bits/s
	0	0	1	1	x	x	x	x	Bit-rate = 1843200 bits/s
	1	1	1	1	x	x	x	x	Bit-rate = User-defined, ref. section 10.5
	x	x	x	x	0	x	x	x	Stop bit = 1
	x	x	x	x	1	x	x	x	Stop bits = 2
	x	x	x	x	x	0	0	x	Parity = none
	x	x	x	x	x	0	1	x	Parity = even
	x	x	x	x	x	1	0	x	Parity = odd
	x	x	x	x	x	x	0	0	Line termination = OFF
x	x	x	x	x	x	x	1	Line termination = ON	
5	x	0	x	x	x	x	x	x	System configuration, Byte 3: Gyro X-axis is inactive
	x	1	x	x	x	x	x	x	Gyro X-axis is active
	x	x	0	x	x	x	x	x	Gyro Y-axis is inactive
	x	x	1	x	x	x	x	x	Gyro Y-axis is active
	x	x	x	0	x	x	x	x	Gyro Z-axis is inactive
	x	x	x	1	x	x	x	x	Gyro Z-axis is active
	x	x	x	x	0	0	0	0	Gyro output unit = ANGULAR RATE
	x	x	x	x	0	0	0	1	Gyro output unit = INCREMENTAL ANGLE
	x	x	x	x	0	0	1	0	Gyro output unit = AVERAGE ANGULAR RATE
	x	x	x	x	0	0	1	1	Gyro output unit = INTEGRATED ANGLE
	x	x	x	x	1	0	0	0	Gyro output unit = ANGULAR RATE – DELAYED
x	x	x	x	1	0	0	1	Gyro output unit = INCREMENTAL ANGLE – DELAYED	
x	x	x	x	1	0	1	0	Gyro output unit = AVERAGE ANGULAR RATE – DELAYED	
x	x	x	x	1	0	1	1	Gyro output unit = INTEGRATED ANGLE – DELAYED	
6	x	0	0	0	x	x	x	x	System configuration, Byte 4: Gyro LP filter -3dB frequency for X-axis = 16Hz
	x	0	0	1	x	x	x	x	Gyro LP filter -3dB frequency for X-axis = 33Hz
	x	0	1	0	x	x	x	x	Gyro LP filter -3dB frequency for X-axis = 66Hz
	x	0	1	1	x	x	x	x	Gyro LP filter -3dB frequency for X-axis = 131Hz
	x	1	0	0	x	x	x	x	Gyro LP filter -3dB frequency for X-axis = 262Hz
	x	x	x	x	x	0	0	0	Gyro LP filter -3dB frequency for Y-axis = 16Hz
	x	x	x	x	x	0	0	1	Gyro LP filter -3dB frequency for Y-axis = 33Hz
	x	x	x	x	x	0	1	0	Gyro LP filter -3dB frequency for Y-axis = 66Hz
	x	x	x	x	x	0	1	1	Gyro LP filter -3dB frequency for Y-axis = 131Hz
	x	x	x	x	x	1	0	0	Gyro LP filter -3dB frequency for Y-axis = 262Hz

7	x	0	0	0	x	x	x	x	System configuration, Byte 5:
	x	0	0	1	x	x	x	x	Gyro LP filter -3dB frequency for Z-axis = 16Hz
	x	0	1	0	x	x	x	x	Gyro LP filter -3dB frequency for Z-axis = 33Hz
	x	0	1	1	x	x	x	x	Gyro LP filter -3dB frequency for Z-axis = 66Hz
	x	1	0	0	x	x	x	x	Gyro LP filter -3dB frequency for Z-axis = 131Hz
	x	x	x	x	0	0	0	0	Gyro LP filter -3dB frequency for Z-axis = 262Hz
	x	x	x	x	0	0	0	1	Gyro g-comp: OFF
	x	x	x	x	0	0	1	0	Gyro g-comp: bias = OFF , scale = ACC
	x	x	x	x	0	0	1	1	Gyro g-comp: bias = OFF , scale = ACC+0.01Hz-filter
	x	x	x	x	0	0	1	1	Gyro g-comp: bias = ACC , scale = OFF
	x	x	x	x	0	1	0	0	Gyro g-comp: bias = ACC+0.01Hz-filter , scale = OFF
	x	x	x	x	0	1	0	1	Gyro g-comp: bias = INC , scale = OFF,
	x	x	x	x	0	1	1	0	Gyro g-comp: bias = INC+0.01Hz-filter, scale = OFF
	x	x	x	x	0	1	1	1	Gyro g-comp: bias = ACC, scale = ACC
	x	x	x	x	1	0	0	0	Gyro g-comp: bias = ACC+0.01Hz-filter , scale = ACC
x	x	x	x	1	0	0	1	Gyro g-comp: bias = INC, scale = ACC	
x	x	x	x	1	0	1	0	Gyro g-comp: bias = INC+DC-filter, scale = ACC	
x	x	x	x	1	0	1	1	Gyro g-comp: bias = ACC+0.01Hz-filter, scale = ACC+0.01Hz-filter	
x	x	x	x	1	1	0	0	Gyro g-comp: bias = INC+0.01Hz-filter, scale = INC+0.01Hz-filter	
x	x	x	x	1	1	1	1	Gyro g-comp: user-defined	
8	x	0	x	x	x	x	x	System configuration, Byte 6:	
	x	1	x	x	x	x	x	Accelerometer X-axis is inactive	
	x	x	0	x	x	x	x	Accelerometer X-axis is active	
	x	x	1	x	x	x	x	Accelerometer Y-axis is inactive	
	x	x	x	0	x	x	x	Accelerometer Y-axis is active	
	x	x	x	1	x	x	x	Accelerometer Z-axis is inactive	
	x	x	x	x	0	0	0	Accelerometer Z-axis is active	
	x	x	x	x	0	0	0	Accelerometer output unit = ACCELERATION	
	x	x	x	x	0	0	1	Accelerometer output unit = INCREMENTAL VELOCITY	
x	x	x	x	0	0	1	0	Accelerometer output unit = AVERAGE ACCELERATION	
x	x	x	x	0	1	1	1	Accelerometer output unit = INTEGRATED VELOCITY	
9	x	0	0	0	x	x	x	System configuration, Byte 7:	
	x	0	0	1	x	x	x	Accelerometer LP filter -3dB frequency for X-axis = 16Hz	
	x	0	1	0	x	x	x	Accelerometer LP filter -3dB frequency for X-axis = 33Hz	
	x	0	1	1	x	x	x	Accelerometer LP filter -3dB frequency for X-axis = 66Hz	
	x	1	0	0	x	x	x	Accelerometer LP filter -3dB frequency for X-axis = 131Hz	
	x	x	x	x	x	0	0	0	Accelerometer LP filter -3dB frequency for X-axis = 262Hz
	x	x	x	x	x	0	0	1	Accelerometer LP filter -3dB frequency for Y-axis = 16Hz
	x	x	x	x	x	0	1	0	Accelerometer LP filter -3dB frequency for Y-axis = 33Hz
	x	x	x	x	x	0	1	1	Accelerometer LP filter -3dB frequency for Y-axis = 66Hz
x	x	x	x	x	1	0	0	Accelerometer LP filter -3dB frequency for Y-axis = 131Hz	
x	x	x	x	x	1	0	0	Accelerometer LP filter -3dB frequency for Y-axis = 262Hz	
10	x	0	0	0	x	x	x	System configuration, Byte 8:	
	x	0	0	1	x	x	x	Accelerometer LP filter -3dB frequency for Z-axis = 16Hz	
	x	0	1	0	x	x	x	Accelerometer LP filter -3dB frequency for Z-axis = 33Hz	
	x	0	1	1	x	x	x	Accelerometer LP filter -3dB frequency for Z-axis = 66Hz	
	x	1	0	0	x	x	x	Accelerometer LP filter -3dB frequency for Z-axis = 131Hz	
x	x	x	x	x	x	x	Accelerometer LP filter -3dB frequency for Z-axis = 262Hz		
11	x	0	x	x	x	x	x	System configuration, Byte 9:	
	x	1	x	x	x	x	x	Inclinometer X-axis is inactive	
	x	x	0	x	x	x	x	Inclinometer X-axis is active	
	x	x	1	x	x	x	x	Inclinometer Y-axis is inactive	
	x	x	x	0	x	x	x	Inclinometer Y-axis is active	
	x	x	x	0	x	x	x	Inclinometer Z-axis is inactive	
	x	x	x	1	x	x	x	Inclinometer Z-axis is active	
	x	x	x	x	0	0	0	0	Inclinometer output unit = ACCELERATION
	x	x	x	x	0	0	0	1	Inclinometer output unit = INCREMENTAL VELOCITY
x	x	x	x	0	0	1	0	Inclinometer output unit = AVERAGE ACCELERATION	
x	x	x	x	0	0	1	1	Inclinometer output unit = INTEGRATED VELOCITY	
12	x	0	0	0	x	x	x	System configuration, Byte 10:	
	x	0	0	1	x	x	x	Inclinometer LP filter -3dB frequency for X-axis = 16Hz	
	x	0	1	0	x	x	x	Inclinometer LP filter -3dB frequency for X-axis = 33Hz	
	x	0	1	1	x	x	x	Inclinometer LP filter -3dB frequency for X-axis = 66Hz	
	x	1	0	0	x	x	x	Inclinometer LP filter -3dB frequency for X-axis = 131Hz	
	x	x	x	x	x	0	0	0	Inclinometer LP filter -3dB frequency for X-axis = 262Hz
	x	x	x	x	x	0	0	1	Inclinometer LP filter -3dB frequency for Y-axis = 16Hz
	x	x	x	x	x	0	1	0	Inclinometer LP filter -3dB frequency for Y-axis = 33Hz
	x	x	x	x	x	0	1	1	Inclinometer LP filter -3dB frequency for Y-axis = 66Hz
x	x	x	x	x	1	0	0	Inclinometer LP filter -3dB frequency for Y-axis = 131Hz	
x	x	x	x	x	1	0	0	Inclinometer LP filter -3dB frequency for Y-axis = 262Hz	
13	x	0	0	0	x	x	x	System configuration, Byte 11:	
	x	0	0	1	x	x	x	Inclinometer LP filter -3dB frequency for Z-axis = 16Hz	
	x	0	1	0	x	x	x	Inclinometer LP filter -3dB frequency for Z-axis = 33Hz	
	x	0	1	1	x	x	x	Inclinometer LP filter -3dB frequency for Z-axis = 66Hz	
	x	1	0	0	x	x	x	Inclinometer LP filter -3dB frequency for Z-axis = 131Hz	
x	1	0	0	x	x	x	Inclinometer LP filter -3dB frequency for Z-axis = 262Hz		

14	x	x	x	x	x	x	x	x	System configuration, Byte 12: For future use
15	0	0	0	0	x	x	x	x	High nibble: Gyro range, x-axis - 400°/s
	x	x	x	x	0	0	0	0	Low nibble: Gyro range, y-axis - 400°/s
16	0	0	0	0	x	x	x	x	High nibble: Gyro range, z-axis - 400°/s
	0	0	0	0	x	x	x	x	High nibble: Accelerometer range, x-axis - 10g
17	x	x	x	x	0	0	0	0	Low nibble: Accelerometer range, y-axis - 10g
	0	0	0	0	x	x	x	x	High nibble: Accelerometer range, z-axis - 10g
19	0	0	0	0	x	x	x	x	High nibble: Inclinator range, x-axis - 1.7g
	x	x	x	x	0	0	0	0	Low nibble: Inclinator range, y-axis - 1.7g
20	0	0	0	0	x	x	x	x	High nibble: Inclinator range, z-axis - 1.7g
	x	x	x	x	x	x	x	x	For future use
22	C ₃₁	C ₃₀	C ₂₉	C ₂₈	C ₂₇	C ₂₆	C ₂₅	C ₂₄	Cyclic Redundancy Check is performed on all preceding bytes, ref. section 6.3.7
23	C ₂₃	C ₂₂	C ₂₁	C ₂₀	C ₁₉	C ₁₈	C ₁₇	C ₁₆	
24	C ₁₅	C ₁₄	C ₁₃	C ₁₂	C ₁₁	C ₁₀	C ₉	C ₈	
25	C ₇	C ₆	C ₅	C ₄	C ₃	C ₂	C ₁	C ₀	
(26)	0	0	0	0	1	1	0	1	<CR> If datagram termination has been selected
(27)	0	0	0	0	1	0	1	0	<LF> If datagram termination has been selected

6.3.4 Bias Trim Offset datagram

Table 6-12: Specification of the Bias Trim Offset datagram

Byte#	Bit#								Specification	
	7	6	5	4	3	2	1	0		
0	1	1	0	1	0	0	0	1	1	Bias Trim Offset datagram identifier: 0xD1 for datagrams without CR+LF termination 0xD2 for datagrams with CR+LF termination
1	Gx ₂₃	Gx ₂₂	Gx ₂₁	Gx ₂₀	Gx ₁₉	Gx ₁₈	Gx ₁₇	Gx ₁₆		X-axis gyro bias trim offset, ref. section 8.4.2.2.2 for conversion to [°/s]. NB: unit is [°/s] regardless of chosen output unit in Normal Mode datagram
2	Gx ₁₅	Gx ₁₄	Gx ₁₃	Gx ₁₂	G ₁₁	Gx ₁₀	Gx ₉	Gx ₈		
3	Gx ₇	Gx ₆	Gx ₅	Gx ₄	Gx ₃	Gx ₂	Gx ₁	Gx ₀		
4	Gy ₂₃	Gy ₂₂	Gy ₂₁	Gy ₂₀	Gy ₁₉	Gy ₁₈	Gy ₁₇	Gy ₁₆		
5	Gy ₁₅	Gy ₁₄	Gy ₁₃	Gy ₁₂	Gy ₁₁	Gy ₁₀	Gy ₉	Gy ₈		Y-axis gyro bias trim offset, ref. section 8.4.2.2.2 for conversion to [°/s]. NB: unit is [°/s] regardless of chosen output unit in Normal Mode datagram
6	Gy ₇	Gy ₆	Gy ₅	Gy ₄	Gy ₃	Gy ₂	Gy ₁	Gy ₀		
7	Gz ₂₃	Gz ₂₂	Gz ₂₁	Gz ₂₀	Gz ₁₉	Gz ₁₈	Gz ₁₇	Gz ₁₆		
8	Gz ₁₅	Gz ₁₄	Gz ₁₃	Gz ₁₂	Gz ₁₁	Gz ₁₀	Gz ₉	Gz ₈		Z-axis gyro bias trim offset, ref. section 8.4.2.2.2 for conversion to [°/s]. NB: unit is [°/s] regardless of chosen output unit in Normal Mode datagram
9	Gz ₇	Gz ₆	Gz ₅	Gz ₄	Gz ₃	Gz ₂	Gz ₁	Gz ₀		
10	Ax ₂₃	Ax ₂₂	Ax ₂₁	Ax ₂₀	Ax ₁₉	Ax ₁₈	Ax ₁₇	Ax ₁₆		X-axis accelerometer bias trim offset, ref. section 8.4.2.2.7 for conversion to [g]. NB: unit is [g] regardless of chosen output unit in Normal Mode datagram
11	Ax ₁₅	Ax ₁₄	Ax ₁₃	Ax ₁₂	Ax ₁₁	Ax ₁₀	Ax ₉	Ax ₈		
12	Ax ₇	Ax ₆	Ax ₅	Ax ₄	Ax ₃	Ax ₂	Ax ₁	Ax ₀		Y-axis accelerometer bias trim offset, ref. section 8.4.2.2.7 for conversion to [g]. NB: unit is [g] regardless of chosen output unit in Normal Mode datagram
13	Ay ₂₃	Ay ₂₂	Ay ₂₁	Ay ₂₀	Ay ₁₉	Ay ₁₈	Ay ₁₇	Ay ₁₆		
14	Ay ₁₅	Ay ₁₄	Ay ₁₃	Ay ₁₂	Ay ₁₁	Ay ₁₀	Ay ₉	Ay ₈		
15	Ay ₇	Ay ₆	Ay ₅	Ay ₄	Ay ₃	Ay ₂	Ay ₁	Ay ₀		
16	Az ₂₃	Az ₂₂	Az ₂₁	Az ₂₀	Az ₁₉	Az ₁₈	Az ₁₇	Az ₁₆		Z-axis accelerometer bias trim offset, ref. section 8.4.2.2.7 for conversion to [g]. NB: unit is [g] regardless of chosen output unit in Normal Mode datagram
17	Az ₁₅	Az ₁₄	Az ₁₃	Az ₁₂	Az ₁₁	Az ₁₀	Az ₉	Az ₈		
18	Az ₇	Az ₆	Az ₅	Az ₄	Az ₃	Az ₂	Az ₁	Az ₀		
19	Ix ₂₃	Ix ₂₂	Ix ₂₁	Ix ₂₀	Ix ₁₉	Ix ₁₈	Ix ₁₇	Ix ₁₆		X-axis Inclinometer bias trim offset, ref. section 8.4.2.2.11 for conversion to [g]. NB: unit is [g] regardless of chosen output unit in Normal Mode datagram
20	Ix ₁₅	Ix ₁₄	Ix ₁₃	Ix ₁₂	Ix ₁₁	Ix ₁₀	Ix ₉	Ix ₈		
21	Ix ₇	Ix ₆	Ix ₅	Ix ₄	Ix ₃	Ix ₂	Ix ₁	Ix ₀		Y-axis Inclinometer bias trim offset, ref. section 8.4.2.2.11 for conversion to [g]. NB: unit is [g] regardless of chosen output unit in Normal Mode datagram
22	Iy ₂₃	Iy ₂₂	Iy ₂₁	Iy ₂₀	Iy ₁₉	Iy ₁₈	Iy ₁₇	Iy ₁₆		
23	Iy ₁₅	Iy ₁₄	Iy ₁₃	Iy ₁₂	Iy ₁₁	Iy ₁₀	Iy ₉	Iy ₈		
24	Iy ₇	Iy ₆	Iy ₅	Iy ₄	Iy ₃	Iy ₂	Iy ₁	Iy ₀		
25	Iz ₂₃	Iz ₂₂	Iz ₂₁	Iz ₂₀	Iz ₁₉	Iz ₁₈	Iz ₁₇	Iz ₁₆		Z-axis Inclinometer bias trim offset, ref. section 8.4.2.2.11 for conversion to [g]. NB: unit is [g] regardless of chosen output unit in Normal Mode datagram
26	Iz ₁₅	Iz ₁₄	Iz ₁₃	Iz ₁₂	Iz ₁₁	Iz ₁₀	Iz ₉	Iz ₈		
27	Iz ₇	Iz ₆	Iz ₅	Iz ₄	Iz ₃	Iz ₂	Iz ₁	Iz ₀		
28	Rf ₃₁	Rf ₃₀	Rf ₂₉	Rf ₂₈	Rf ₂₇	Rf ₂₆	Rf ₂₅	Rf ₂₄		Reference info to last adjustment
29	Rf ₂₃	Rf ₂₂	Rf ₂₁	Rf ₂₀	Rf ₁₉	Rf ₁₈	Rf ₁₇	Rf ₁₆		
30	Rf ₁₅	Rf ₁₄	Rf ₁₃	Rf ₁₂	Rf ₁₁	Rf ₁₀	Rf ₉	Rf ₈		
31	Rf ₇	Rf ₆	Rf ₅	Rf ₄	Rf ₃	Rf ₂	Rf ₁	Rf ₀		
32	Sav ₁₅	Sav ₁₄	Sav ₁₃	Sav ₁₂	Sav ₁₁	Sav ₁₀	Sav ₉	Sav ₈		Remaining number of saves
33	Sav ₇	Sav ₆	Sav ₅	Sav ₄	Sav ₃	Sav ₂	Sav ₁	Sav ₀		
34	x	x	x	x	x	x	x	x		For future use
35	x	x	x	x	x	x	x	x		For future use
36	C ₃₁	C ₃₀	C ₂₉	C ₂₈	C ₂₇	C ₂₆	C ₂₅	C ₂₄		Cyclic Redundancy Check is performed on all preceding bytes, ref. section 6.3.7
37	C ₂₃	C ₂₂	C ₂₁	C ₂₀	C ₁₉	C ₁₈	C ₁₇	C ₁₆		
38	C ₁₅	C ₁₄	C ₁₃	C ₁₂	C ₁₁	C ₁₀	C ₉	C ₈		
39	C ₇	C ₆	C ₅	C ₄	C ₃	C ₂	C ₁	C ₀		
(40)	0	0	0	0	1	1	0	1		<CR> If datagram termination has been selected
(41)	0	0	0	0	1	0	1	0		<LF> If datagram termination has been selected

6.3.5 Extended Error Information datagram

Table 6-13: Specification of the Extended Error Information datagram

Byte#	Bit#								Specification
	7	6	5	4	3	2	1	0	
0	1 1	0 0	1 1	1 1	1 1	1 1	1 1	0 1	Extended Error Information datagram identifier: 0xBE for datagrams without CR+LF termination 0xBF for datagrams with CR+LF termination
1	E ₁₂₇	E ₁₂₆	E ₁₂₅	E ₁₂₄	E ₁₂₃	E ₁₂₂	E ₁₂₁	E ₁₂₀	Ref. Table 6-14
2	E ₁₁₉	E ₁₁₈	E ₁₁₇	E ₁₁₆	E ₁₁₅	E ₁₁₄	E ₁₁₃	E ₁₁₂	Ref. Table 6-14
3	E ₁₁₁	E ₁₁₀	E ₁₀₉	E ₁₀₈	E ₁₀₇	E ₁₀₆	E ₁₀₅	E ₁₀₄	Ref. Table 6-14
4	E ₁₀₃	E ₁₀₂	E ₁₀₁	E ₁₀₀	E ₉₉	E ₉₈	E ₉₇	E ₉₆	Ref. Table 6-14
5	E ₉₅	E ₉₄	E ₉₃	E ₉₂	E ₉₁	E ₉₀	E ₈₉	E ₈₈	Ref. Table 6-14
6	E ₈₇	E ₈₆	E ₈₅	E ₈₄	E ₈₃	E ₈₂	E ₈₁	E ₈₀	Ref. Table 6-14
7	E ₇₉	E ₇₈	E ₇₇	E ₇₆	E ₇₅	E ₇₄	E ₇₃	E ₇₂	Ref. Table 6-14
8	E ₇₁	E ₇₀	E ₆₉	E ₆₈	E ₆₇	E ₆₆	E ₆₅	E ₆₄	Ref. Table 6-14
9	E ₆₃	E ₆₂	E ₆₁	E ₆₀	E ₅₉	E ₅₈	E ₅₇	E ₅₆	Ref. Table 6-14
10	E ₅₅	E ₅₄	E ₅₃	E ₅₂	E ₅₁	E ₅₀	E ₄₉	E ₄₈	Ref. Table 6-14
11	E ₄₇	E ₄₆	E ₄₅	E ₄₄	E ₄₃	E ₄₂	E ₄₁	E ₄₀	Ref. Table 6-14
12	E ₃₉	E ₃₈	E ₃₇	E ₃₆	E ₃₅	E ₃₄	E ₃₃	E ₃₂	Ref. Table 6-14
13	E ₃₁	E ₃₀	E ₂₉	E ₂₈	E ₂₇	E ₂₆	E ₂₅	E ₂₄	Ref. Table 6-14
14	E ₂₃	E ₂₂	E ₂₁	E ₂₀	E ₁₉	E ₁₈	E ₁₇	E ₁₆	Ref. Table 6-14
15	E ₁₅	E ₁₄	E ₁₃	E ₁₂	E ₁₁	E ₁₀	E ₉	E ₈	Ref. Table 6-14
16	E ₇	E ₆	E ₅	E ₄	E ₃	E ₂	E ₁	E ₀	Ref. Table 6-14
17	C ₃₁	C ₃₀	C ₂₉	C ₂₈	C ₂₇	C ₂₆	C ₂₅	C ₂₄	Cyclic Redundancy Check is performed on all preceding bytes, ref. section 6.3.7
18	C ₂₃	C ₂₂	C ₂₁	C ₂₀	C ₁₉	C ₁₈	C ₁₇	C ₁₆	
19	C ₁₅	C ₁₄	C ₁₃	C ₁₂	C ₁₁	C ₁₀	C ₉	C ₈	
20	C ₇	C ₆	C ₅	C ₄	C ₃	C ₂	C ₁	C ₀	
(21)	0	0	0	0	1	1	0	1	<CR> If datagram termination has been selected
(22)	0	0	0	0	1	0	1	0	<LF> If datagram termination has been selected

Table 6-14: Specification of the Extended Error Information

Bit#	Specification	Bit#	Specification	Bit#	Specification	Bit#	Specification
E ₁₂₇	For future use (=0)	E ₁₂₆	For future use (=0)	E ₁₂₅	For future use (=0)	E ₁₂₄	For future use (=0)
E ₁₂₃	For future use (=0)	E ₁₂₂	For future use (=0)	E ₁₂₁	For future use (=0)	E ₁₂₀	For future use (=0)
E ₁₁₉	For future use (=0)	E ₁₁₈	For future use (=0)	E ₁₁₇	For future use (=0)	E ₁₁₆	For future use (=0)
E ₁₁₅	For future use (=0)	E ₁₁₄	For future use (=0)	E ₁₁₃	For future use (=0)	E ₁₁₂	For future use (=0)
E ₁₁₁	Reference voltage#4 error	E ₁₁₀	For future use (=0)	E ₁₀₉	INC Z: Overload	E ₁₀₈	INC Y: Overload
E ₁₀₇	INC X: Overload	E ₁₀₆	ACC Z: Overload	E ₁₀₅	ACC Y: Overload	E ₁₀₄	ACC X: Overload
E ₁₀₃	GYRO Z: Overload	E ₁₀₂	GYRO Y: Overload	E ₁₀₁	GYRO X: Overload	E ₁₀₀	GYRO Z: Config.error
E ₉₉	GYRO Y: Config.error	E ₉₈	GYRO X: Config.error	E ₉₇	µC temperature failure	E ₉₆	GYRO Z: ASIC temp.dev.
E ₉₅	GYRO Y: ASIC temp.dev	E ₉₄	GYRO X: ASIC temp.dev	E ₉₃	INC Y: Temp.deviation	E ₉₂	INC X/Z: Temp.deviation
E ₉₁	ACC Z: Temp.deviation	E ₉₀	ACC Y: Temp.deviation	E ₈₉	ACC X: Temp.deviation	E ₈₈	GYRO Z: Temp.deviation
E ₈₇	GYRO Y: Temp.deviation	E ₈₆	GYRO X: Temp.deviation	E ₈₅	Self-test not running	E ₈₄	TEMP INC Y: ADC error
E ₈₃	TEMP INC X/Z: ADC error	E ₈₂	TEMP ACC Z: ADC error	E ₈₁	TEMP ACC Y: ADC error	E ₈₀	TEMP ACC X: ADC error
E ₇₉	TEMP GYRO Z: Clipped	E ₇₈	TEMP GYRO Y: Clipped	E ₇₇	TEMP GYRO X: Clipped	E ₇₆	For future use (=0)
E ₇₅	INC Z: ADC error	E ₇₄	INC Y: ADC error	E ₇₃	INC X: ADC error	E ₇₂	ACC Z: ADC error
E ₇₁	ACC Y: ADC error	E ₇₀	ACC X: ADC error	E ₆₉	For future use (=0)	E ₆₈	UART unable to transmit
E ₆₇	GYRO Z: data missing	E ₆₆	GYRO Y: Data missing	E ₆₅	GYRO X: Data missing	E ₆₄	Transmit stack warning
E ₆₃	Flash stack warning	E ₆₂	Sample stack warning	E ₆₁	Command stack warning	E ₆₀	Monitor stack warning
E ₅₉	Supply overvoltage	E ₅₈	Internal DAC error	E ₅₇	Flash check error	E ₅₆	RAM check error
E ₅₅	TEMP INC Y: Error	E ₅₄	TEMP INC X/Z: Error	E ₅₃	INC Z: Clipped	E ₅₂	INC Y: Clipped
E ₅₁	INC X: Clipped	E ₅₀	TEMP ACC Z: Error	E ₄₉	TEMP ACC Y: Error	E ₄₈	TEMP ACC X: Error
E ₄₇	ACC Z: Clipped	E ₄₆	ACC Y: Clipped	E ₄₅	ACC X: Clipped	E ₄₄	GYRO Z: Data lost
E ₄₃	GYRO Z: Exc.ampl.error	E ₄₂	GYRO Z: Int.comm.error	E ₄₁	For future use (=0)	E ₄₀	For future use (=0)
E ₃₉	GYRO Z: ASIC overflow, I	E ₃₈	GYRO Z: ASIC overflow, Q	E ₃₇	GYRO Y: Data lost	E ₃₆	GYRO Y: Exc.ampl.error
E ₃₅	GYRO Y: Int.comm.error	E ₃₄	For future use (=0)	E ₃₃	For future use (=0)	E ₃₂	GYRO Y: ASIC overflow, I
E ₃₁	GYRO Y: ASIC overflow, Q	E ₃₀	GYRO X: Data lost	E ₂₉	GYRO X: Exc.ampl.error	E ₂₈	GYRO X: Int.comm.error
E ₂₇	For future use (=0)	E ₂₆	For future use (=0)	E ₂₅	GYRO X: ASIC overflow, I	E ₂₄	GYRO X: ASIC overflow, Q
E ₂₃	Regulated voltage#3 error	E ₂₂	Regulated voltage#2 error	E ₂₁	Regulated voltage#1 error	E ₂₀	Supply voltage error
E ₁₉	Reference voltage#3 error	E ₁₈	Reference voltage#2 error	E ₁₇	Reference voltage#1 error	E ₁₆	Start-up phase active
E ₁₅	GYRO Z: Int.comm.error	E ₁₄	GYRO Y: Int.comm.error	E ₁₃	GYRO X: Int.comm.error	E ₁₂	GYRO Z: Clipped
E ₁₁	GYRO Y: Clipped	E ₁₀	GYRO X: Clipped	E ₉	TEMP GYRO Z: Error	E ₈	TEMP GYRO Y: Error
E ₇	TEMP GYRO X: Error	E ₆	GYRO Z: ASIC temp.error	E ₅	GYRO Y: ASIC temp.error	E ₄	GYRO X: ASIC temp.error
E ₃	µC temperature error	E ₂	GYRO Z: Exc.freq.error	E ₁	GYRO Y: Exc.freq.error	E ₀	GYRO X: Exc.freq.error

6.3.6 Normal Mode datagram

Table 6-15: Specification of the Normal Mode datagram (full data content in datagram)

Byte#	Bit#								Specification	
	7	6	5	4	3	2	1	0		
0	1	0	1	0	1	1	1	1	Normal Mode datagram identifier for Normal Mode datagram with full content. Identifier for reduced content datagrams can be found in Table 6-16	
1	Gx ₂₃	Gx ₂₂	Gx ₂₁	Gx ₂₀	Gx ₁₉	Gx ₁₈	Gx ₁₇	Gx ₁₆	X-axis gyro output, ref. sections 8.4.2.2.2 to 8.4.2.2.5 for conversion to units	
2	Gx ₁₅	Gx ₁₄	Gx ₁₃	Gx ₁₂	G ₁₁	Gx ₁₀	Gx ₉	Gx ₈		
3	Gx ₇	Gx ₆	Gx ₅	Gx ₄	Gx ₃	Gx ₂	Gx ₁	Gx ₀		
4	Gy ₂₃	Gy ₂₂	Gy ₂₁	Gy ₂₀	Gy ₁₉	Gy ₁₈	Gy ₁₇	Gy ₁₆		
5	Gy ₁₅	Gy ₁₄	Gy ₁₃	Gy ₁₂	Gy ₁₁	Gy ₁₀	Gy ₉	Gy ₈	Y-axis gyro output, ref. sections 8.4.2.2.2 to 8.4.2.2.5 for conversion to units	
6	Gy ₇	Gy ₆	Gy ₅	Gy ₄	Gy ₃	Gy ₂	Gy ₁	Gy ₀		
7	Gz ₂₃	Gz ₂₂	Gz ₂₁	Gz ₂₀	Gz ₁₉	Gz ₁₈	Gz ₁₇	Gz ₁₆		
8	Gz ₁₅	Gz ₁₄	Gz ₁₃	Gz ₁₂	Gz ₁₁	Gz ₁₀	Gz ₉	Gz ₈		
9	Gz ₇	Gz ₆	Gz ₅	Gz ₄	Gz ₃	Gz ₂	Gz ₁	Gz ₀	Z-axis gyro output, ref. sections 8.4.2.2.2 to 8.4.2.2.5 for conversion to units	
10	Gs ₇	Gs ₆	Gs ₅	Gs ₄	Gs ₃	Gs ₂	Gs ₁	Gs ₀		
11	Ax ₂₃	Ax ₂₂	Ax ₂₁	Ax ₂₀	Ax ₁₉	Ax ₁₈	Ax ₁₇	Ax ₁₆		X-axis accelerometer output, ref. sections 8.4.2.2.7 to 8.4.2.2.10 for conversion to units
12	Ax ₁₅	Ax ₁₄	Ax ₁₃	Ax ₁₂	Ax ₁₁	Ax ₁₀	Ax ₉	Ax ₈		
13	Ax ₇	Ax ₆	Ax ₅	Ax ₄	Ax ₃	Ax ₂	Ax ₁	Ax ₀		
14	Ay ₂₃	Ay ₂₂	Ay ₂₁	Ay ₂₀	Ay ₁₉	Ay ₁₈	Ay ₁₇	Ay ₁₆		
15	Ay ₁₅	Ay ₁₄	Ay ₁₃	Ay ₁₂	Ay ₁₁	Ay ₁₀	Ay ₉	Ay ₈	Y-axis accelerometer output, ref. sections 8.4.2.2.7 to 8.4.2.2.10 for conversion to units	
16	Ay ₇	Ay ₆	Ay ₅	Ay ₄	Ay ₃	Ay ₂	Ay ₁	Ay ₀		
17	Az ₂₃	Az ₂₂	Az ₂₁	Az ₂₀	Az ₁₉	Az ₁₈	Az ₁₇	Az ₁₆		
18	Az ₁₅	Az ₁₄	Az ₁₃	Az ₁₂	Az ₁₁	Az ₁₀	Az ₉	Az ₈		
19	Az ₇	Az ₆	Az ₅	Az ₄	Az ₃	Az ₂	Az ₁	Az ₀	Z-axis accelerometer output, ref. sections 8.4.2.2.7 to 8.4.2.2.10 for conversion to units	
20	As ₇	As ₆	As ₅	As ₄	As ₃	As ₂	As ₁	As ₀		
21	Ix ₂₃	Ix ₂₂	Ix ₂₁	Ix ₂₀	Ix ₁₉	Ix ₁₈	Ix ₁₇	Ix ₁₆		X-axis Inclinomometer output, ref. sections 8.4.2.2.11 to 8.4.2.2.14 for conversion to units
22	Ix ₁₅	Ix ₁₄	Ix ₁₃	Ix ₁₂	Ix ₁₁	Ix ₁₀	Ix ₉	Ix ₈		
23	Ix ₇	Ix ₆	Ix ₅	Ix ₄	Ix ₃	Ix ₂	Ix ₁	Ix ₀		
24	Iy ₂₃	Iy ₂₂	Iy ₂₁	Iy ₂₀	Iy ₁₉	Iy ₁₈	Iy ₁₇	Iy ₁₆		
25	Iy ₁₅	Iy ₁₄	Iy ₁₃	Iy ₁₂	Iy ₁₁	Iy ₁₀	Iy ₉	Iy ₈	Y-axis Inclinomometer output, ref. sections 8.4.2.2.11 to 8.4.2.2.14 for conversion to units	
26	Iy ₇	Iy ₆	Iy ₅	Iy ₄	Iy ₃	Iy ₂	Iy ₁	Iy ₀		
27	Iz ₂₃	Iz ₂₂	Iz ₂₁	Iz ₂₀	Iz ₁₉	Iz ₁₈	Iz ₁₇	Iz ₁₆		
28	Iz ₁₅	Iz ₁₄	Iz ₁₃	Iz ₁₂	Iz ₁₁	Iz ₁₀	Iz ₉	Iz ₈		
29	Iz ₇	Iz ₆	Iz ₅	Iz ₄	Iz ₃	Iz ₂	Iz ₁	Iz ₀	Z-axis Inclinomometer output, ref. sections 8.4.2.2.11 to 8.4.2.2.14 for conversion to units	
30	Is ₇	Is ₆	Is ₅	Is ₄	Is ₃	Is ₂	Is ₁	Is ₀		
31	GTX ₁₅	GTX ₁₄	GTX ₁₃	GTX ₁₂	GTX ₁₁	GTX ₁₀	GTX ₉	GTX ₈		X-axis gyro temperature data, ref. section 8.4.2.2.15 for conversion to units
32	GTX ₇	GTX ₆	GTX ₅	GTX ₄	GTX ₃	GTX ₂	GTX ₁	GTX ₀		
33	GTY ₁₅	GTY ₁₄	GTY ₁₃	GTY ₁₂	GTY ₁₁	GTY ₁₀	GTY ₉	GTY ₈		
34	GTY ₇	GTY ₆	GTY ₅	GTY ₄	GTY ₃	GTY ₂	GTY ₁	GTY ₀		
35	GTZ ₁₅	GTZ ₁₄	GTZ ₁₃	GTZ ₁₂	GTZ ₁₁	GTZ ₁₀	GTZ ₉	GTZ ₈	Z-axis gyro temperature data, ref. section 8.4.2.2.15 for conversion to units	
36	GTZ ₇	GTZ ₆	GTZ ₅	GTZ ₄	GTZ ₃	GTZ ₂	GTZ ₁	GTZ ₀		
37	GTS ₇	GTS ₆	GTS ₅	GTS ₄	GTS ₃	GTS ₂	GTS ₁	GTS ₀		
38	ATX ₁₅	ATX ₁₄	ATX ₁₃	ATX ₁₂	ATX ₁₁	ATX ₁₀	ATX ₉	ATX ₈		
39	ATX ₇	ATX ₆	ATX ₅	ATX ₄	ATX ₃	ATX ₂	ATX ₁	ATX ₀	X-axis accelerometer temperature data, ref. section 8.4.2.2.15 for conversion to units	
40	ATY ₁₅	ATY ₁₄	ATY ₁₃	ATY ₁₂	ATY ₁₁	ATY ₁₀	ATY ₉	ATY ₈		
41	ATY ₇	ATY ₆	ATY ₅	ATY ₄	ATY ₃	ATY ₂	ATY ₁	ATY ₀		
42	ATZ ₁₅	ATZ ₁₄	ATZ ₁₃	ATZ ₁₂	ATZ ₁₁	ATZ ₁₀	ATZ ₉	ATZ ₈		
43	ATZ ₇	ATZ ₆	ATZ ₅	ATZ ₄	ATZ ₃	ATZ ₂	ATZ ₁	ATZ ₀	Z-axis accelerometer temperature data, ref. section 8.4.2.2.15 for conversion to units	
44	ATS ₇	ATS ₆	ATS ₅	ATS ₄	ATS ₃	ATS ₂	ATS ₁	ATS ₀		
45	ITX ₁₅	ITX ₁₄	ITX ₁₃	ITX ₁₂	ITX ₁₁	ITX ₁₀	ITX ₉	ITX ₈		
46	ITX ₇	ITX ₆	ITX ₅	ITX ₄	ITX ₃	ITX ₂	ITX ₁	ITX ₀		
47	ITY ₁₅	ITY ₁₄	ITY ₁₃	ITY ₁₂	ITY ₁₁	ITY ₁₀	ITY ₉	ITY ₈	Y-axis inclinometer temperature data, ref. section 8.4.2.2.15 for conversion to units	
48	ITY ₇	ITY ₆	ITY ₅	ITY ₄	ITY ₃	ITY ₂	ITY ₁	ITY ₀		
49	ITZ ₁₅	ITZ ₁₄	ITZ ₁₃	ITZ ₁₂	ITZ ₁₁	ITZ ₁₀	ITZ ₉	ITZ ₈		
50	ITZ ₇	ITZ ₆	ITZ ₅	ITZ ₄	ITZ ₃	ITZ ₂	ITZ ₁	ITZ ₀		
51	ITS ₇	ITS ₆	ITS ₅	ITS ₄	ITS ₃	ITS ₂	ITS ₁	ITS ₀	STATUS byte for inclinometer temperature measurements, ref. Table 6-18	
52	n ₇	n ₆	n ₅	n ₄	n ₃	n ₂	n ₁	n ₀		
53	t ₁₅	t ₁₄	t ₁₃	t ₁₂	t ₁₁	t ₁₀	t ₉	t ₈		
54	t ₇	t ₆	t ₅	t ₄	t ₃	t ₂	t ₁	t ₀		
55	C ₃₁	C ₃₀	C ₂₉	C ₂₈	C ₂₇	C ₂₆	C ₂₅	C ₂₄	Cyclic Redundancy Check is performed on all preceding bytes, ref. section 6.3.7	
56	C ₂₃	C ₂₂	C ₂₁	C ₂₀	C ₁₉	C ₁₈	C ₁₇	C ₁₆		
57	C ₁₅	C ₁₄	C ₁₃	C ₁₂	C ₁₁	C ₁₀	C ₉	C ₈		
58	C ₇	C ₆	C ₅	C ₄	C ₃	C ₂	C ₁	C ₀		
(59)	0	0	0	0	1	1	0	1	<CR> If datagram termination has been selected	
(60)	0	0	0	0	1	0	1	0	<LF> If datagram termination has been selected	

Normal Mode datagrams with reduced content can be chosen at order or configured in Service Mode. Overview of available datagrams can be found in Table 6-16 and in section 13. When choosing a Normal mode datagram with reduced content, the Normal Mode datagram will be shorter. However the order of requested data will be transmitted

as shown in Table 6-15. When selecting temperature in the datagram, only temperatures for the selected measurement-clusters will be transmitted, e.g. if gyro and inclinometer data have been chosen together with temperature, only temperatures for the gyros and inclinometers will be transmitted.

Table 6-16: Normal Mode datagram identifiers

Datagram content	Identifier
Rate	0x90
Rate and acceleration	0x91
Rate and inclination	0x92
Rate, acceleration and inclination	0x93
Rate and temperature	0x94
Rate, acceleration and temperature	0xA5
Rate, inclination and temperature	0xA6
Rate, acceleration, inclination and temperature	0xA7

6.3.7 Cyclic Redundancy Check (CRC)

At the end of all datagrams is a 32-bit Cyclic Redundancy Checksum. The CRC checksum enables the user to detect errors in the transfer of data from STIM318. The CRC is calculated using the following equation:

$$x^{32} + x^{26} + x^{23} + x^{22} + x^{16} + x^{12} + x^{11} + x^{10} + x^8 + x^7 + x^5 + x^4 + x^2 + x + 1$$

seed = 0xFFFFFFFF

All preceding data, including the datagram identifier, is included in the CRC.

The CRC-algorithm requires full sets of 32-bits (4 bytes). Several of the defined datagrams from STIM318 have a length which is not an integer number of 4 bytes. In order to have an efficient transmission of data and thereby avoid transmitting bytes with no meaningful content, dummy-byte(s) with content = 0x00 are added when the CRC of the last byte(s) is calculated.

Example: Datagram with ID=0xA7 (rate, acceleration, inclination and temperature) has been chosen. This datagram consists of 55 bytes prior to the CRC checksum. Hence this datagram consists of 13 sets of 32 bits + 3 bytes. In order to include the last 3 bytes in the CRC checksum, 1 byte = 0x00 is added, making the last data byte the least significant byte.

Table 6-17 lists the number of dummy-bytes needed to calculate the final CRC-checksum for the different datagrams in Normal Mode.

Table 6-17: Number of dummy-bytes to be added for CRC-calculation

Datagram content	Identifier	# dummy-bytes
Part Number datagram	0xB1, 0xB3	0
Serial Number datagram	0xB5, 0xB7	0
Configuration datagram	0xBC, 0xBD	2
Extended Error Information datagram	0xBE, 0xBF	3
Bias Trim offset datagram	0xD1, 0xD2	0
Rate	0x90	2
Rate and acceleration	0x91	0
Rate and inclination	0x92	0
Rate, acceleration and inclination	0x93	2
Rate and temperature	0x94	3
Rate, acceleration and temperature	0xA5	2
Rate, inclination and temperature	0xA6	2
Rate, acceleration, inclination and temperature	0xA7	1

6.4 Status byte

Table 6-18: Interpretation of bits in STATUS byte

Bit	STATUS bit information	Comment
7	0=OK, 1=System integrity error	Bits 0-2 will flag the overload channel(s) Bits 0-2 will flag the error channel(s)
6	0=OK, 1=Start-Up	
5	0=OK, 1=Outside operating conditions	
4	0=OK, 1=Overload	
3	0=OK, 1=Error in measurement-channel	
2	0=OK, 1=Z-channel	
1	0=OK, 1=Y-channel	
0	0=OK, 1=X-channel	

Refer to section 8.5 for more information related to the self-diagnostics of STIM318.

7 MECHANICAL

Table 7-1: Mechanical specifications

Parameter	Conditions	Min	Nom	Max	Unit	Note
HOUSING MATERIAL		Aluminium, Alloy 6082-T6, DIN EN 754-2				
SURFACE TREATMENT Passivation		Surtec 650				1
WEIGHT		57			grams	
VOLUME		32.6 1.99			ccm cu in	
DUST AND HUMIDITY CLASSIFICATION		IP67				
CONNECTOR Type Number of pins Contact type		Micro-D 15 female				
PLUG Proposed plug to fit connector Proposed cover to fit plug	For best EMI performance	Axon MDA 2 15 P Axon micro-D EMI back shell				
FIXATION BOLTS Recommended torque	Steel base Aluminium base	M4 ISO 4762 / DIN 912 3.5 3.0			Nm Nm	

Note 1: Hexavalent chromium free

7.1 Mechanical dimensions

All dimensions are in mm.

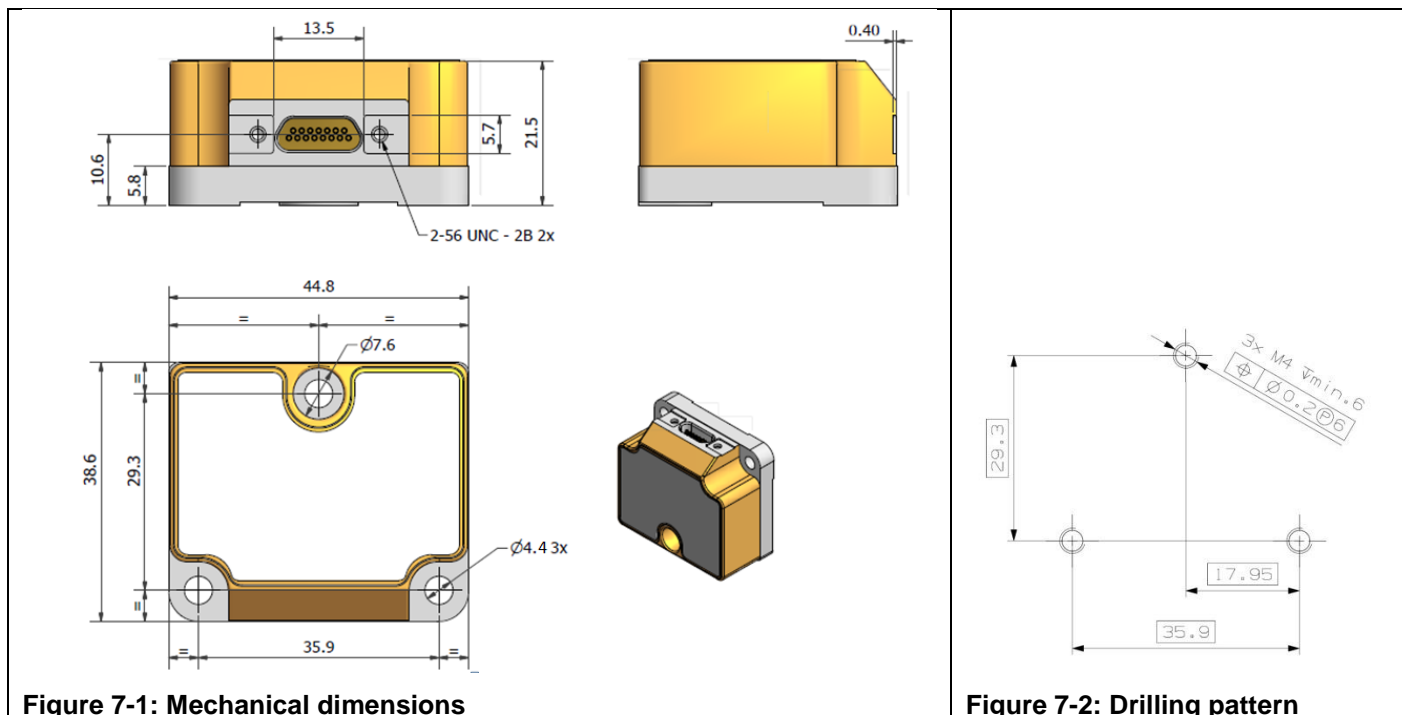

Figure 7-1: Mechanical dimensions

Figure 7-2: Drilling pattern

Table 7-2: Nominal position of accelerometer mass-centers (ref. Figure 6-2 for reference definition)

Axis	X-offset	Y-offset	Z-offset
X	-32.3	-10.2	12.0
Y	-26.5	-6.3	13.1
Z	-27.1	-10.7	6.8

7.2 Advice on mounting orientation

The gyros are sensitive to acceleration-forces in certain directions:

- X- and Y-gyros have their highest sensitivity to acceleration-forces in Z-direction
- Z-gyro has its highest sensitivity to acceleration-forces in Y-direction
- X-gyro has its lowest sensitivity to acceleration-forces in X-direction
- Y-gyro has its lowest sensitivity to acceleration-forces in Y-direction
- Z-gyro has its lowest sensitivity to acceleration-forces in Z-direction

7.3 Pin configuration

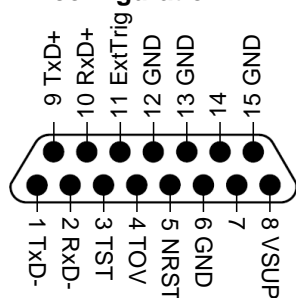

Figure 7-3: Pin configuration as seen from front of STIM318

Table 7-3: Pin descriptions

Pin#	Label	Type	Description
1	TxD-	OUTPUT	RS422 negative output
2	RxD-	INPUT	RS422 negative input
3	TST	OUTPUT	Test pin: Do not connect
4	TOV	OUTPUT	Time of Validity (if not in use, leave floating)
5	NRST	INPUT	Reset (if not in use, connect to VSUP or leave floating)
6	GND	SUPPLY	Internally connected to Power ground (0V)
7			Not connected
8	VSUP	SUPPLY	Power supply (+5V)
9	TxD+	OUTPUT	RS422 positive output
10	RxD+	INPUT	RS422 positive input
11	ExtTrig	INPUT	External trigger (if not in use, connect to VSUP or leave floating)
12	GND	INPUT	Test pin: Connect to ground (0V)
13	GND	INPUT	Test pin: Connect to ground (0V)
14			Not connected
15	GND	SUPPLY	Power ground (0V)

7.4 Definition of axes

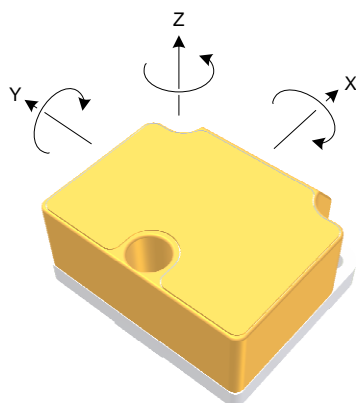

Figure 7-4: Definition of axes

8 BASIC OPERATION

STIM318 is very simple to use. Unless having been configured with external trigger, the unit will start performing measurements and transmit the results over the RS422 interface without any need for additional signalling or set-up after power-on. Figure 8-1 shows the simplest connection set-up for STIM318.

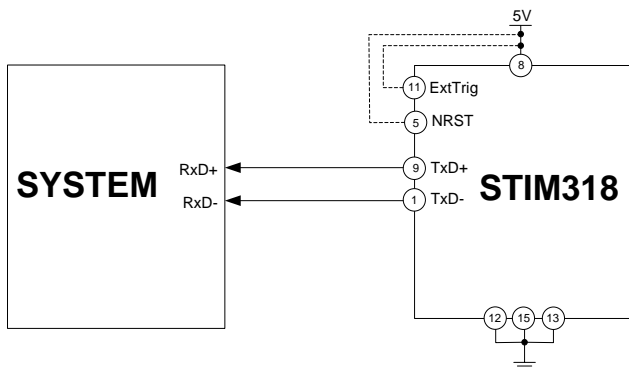

Figure 8-1: Transmit-Only Electrical Connection Diagram

In order to take full advantage of all features of STIM318, the unit needs to be connected as shown in Figure 8-2. In this set-up the system can reset the unit without having to toggle power, the external trigger function can be utilized, configuration parameters can be changed and extended information like diagnostic information can be read from the device.

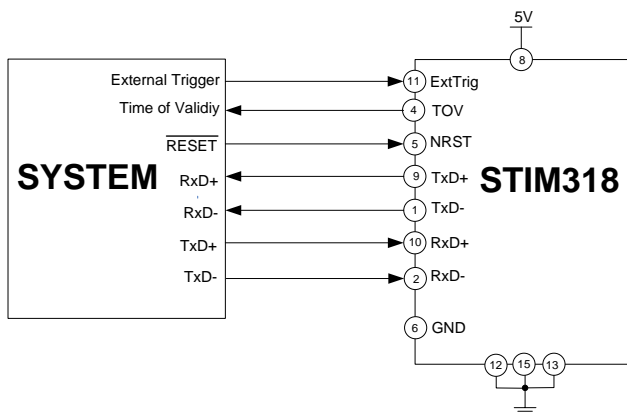

Figure 8-2: Full Function Electrical Connection Diagram

8.1 Reset

STIM318 has a separate reset pin (NRST) in order for the application to reset the unit without having to toggle power. The reset is active low and has an internal pull-up. Hence the input could be left floating if not in use.

The reset signal is routed to the reset of the microcontroller and effectively forces STIM318 into Init Mode (ref. Figure 8-6 and section 8.4.1).

8.2 External Trigger

STIM318 has a separate digital input pin to be used when the unit has been configured to transmit only upon external trigger. The measurements themselves will be continuously running at the highest sample rate (2000 samples/s) in order to ensure shortest possible latency when a transmission is requested. The input is set to trigger on the falling edge of the input signal and will then transmit one datagram containing the result of the latest measurement.

The input has an internal pull-up. Hence the input could be left floating if not in use.

Note that when requesting one of the special Normal Mode datagrams, ref. section 9, the datagram will be transmitted at the next external trigger input, replacing the datagram containing sensor data. If several requests for special datagrams are issued prior to an external trigger, it will be the last requested special datagram that will be transmitted.

When STIM318 is in Init Mode (after Power on or Reset), it will transmit the special datagrams as described in section 8.4.1 regardless of external trigger input.

The timing diagram is shown in Figure 8-3. Latency is the time between the moment at which the sample has been digitized + low pass-filtered and the receipt of the external trigger.

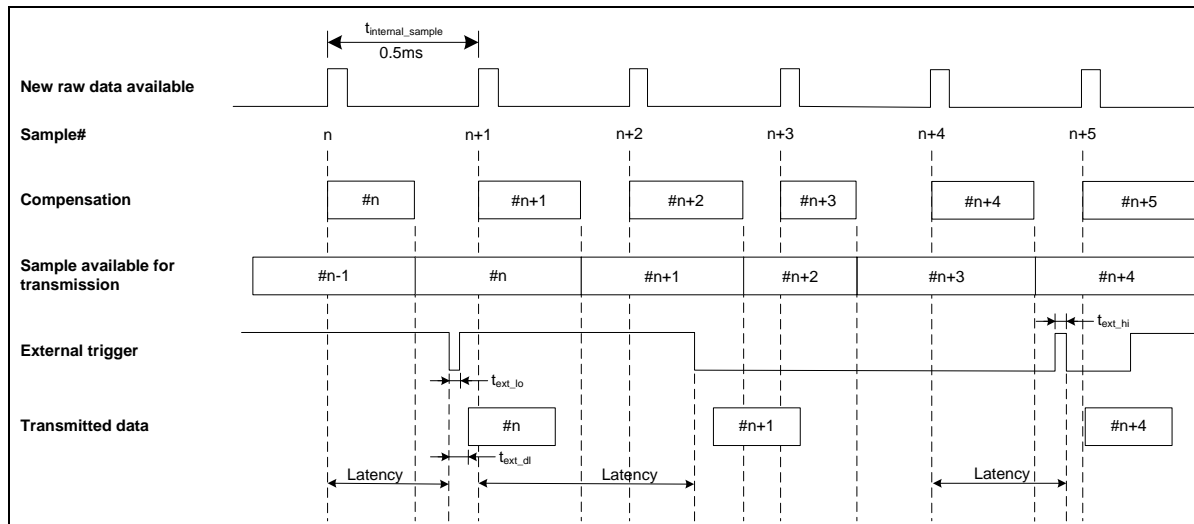

Figure 8-3: Timing of external trigger

8.3 Time of Validity (TOV)

The TOV-output serves 2 purposes:

- Provide a synchronisation-signal derived from the internal clock of STIM318
- Provide means to signal when a datagram is being transmitted (NB: not when configured to external trigger)

The TOV falling edge occurs synchronous to the sample rate. The raising edge occurs after the last bit of the datagram has been transmitted.

Figure 8-4 and Figure 8-5 show the timing diagram of the TOV-output.

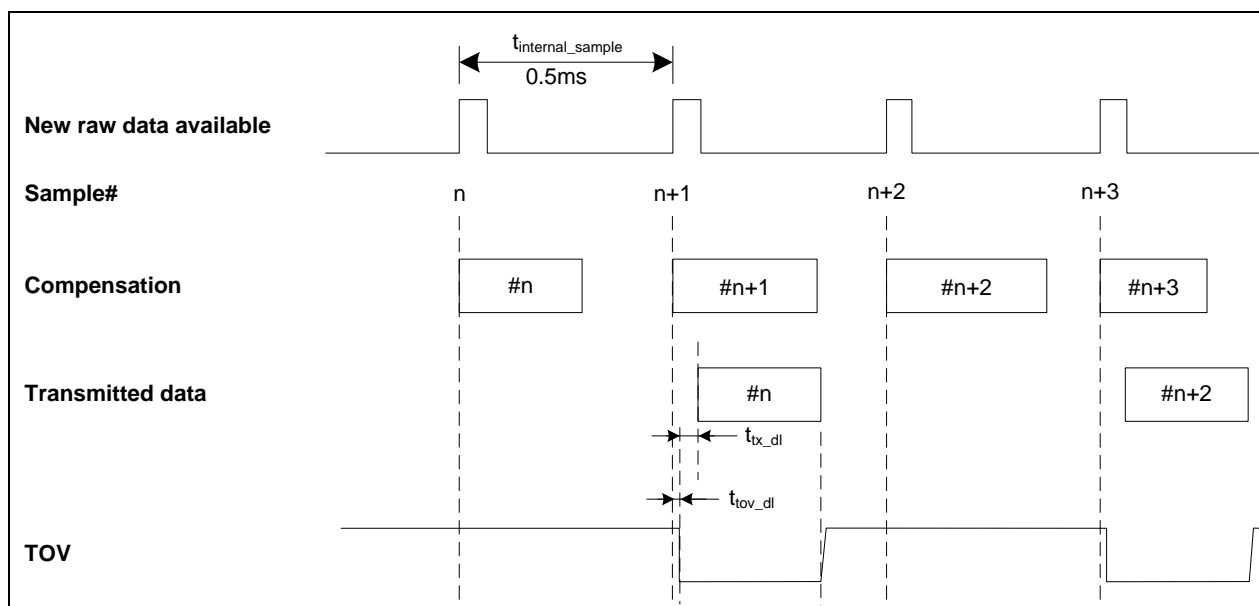

Figure 8-4: Timing of TOV (example: sample rate = 1000samples/s)

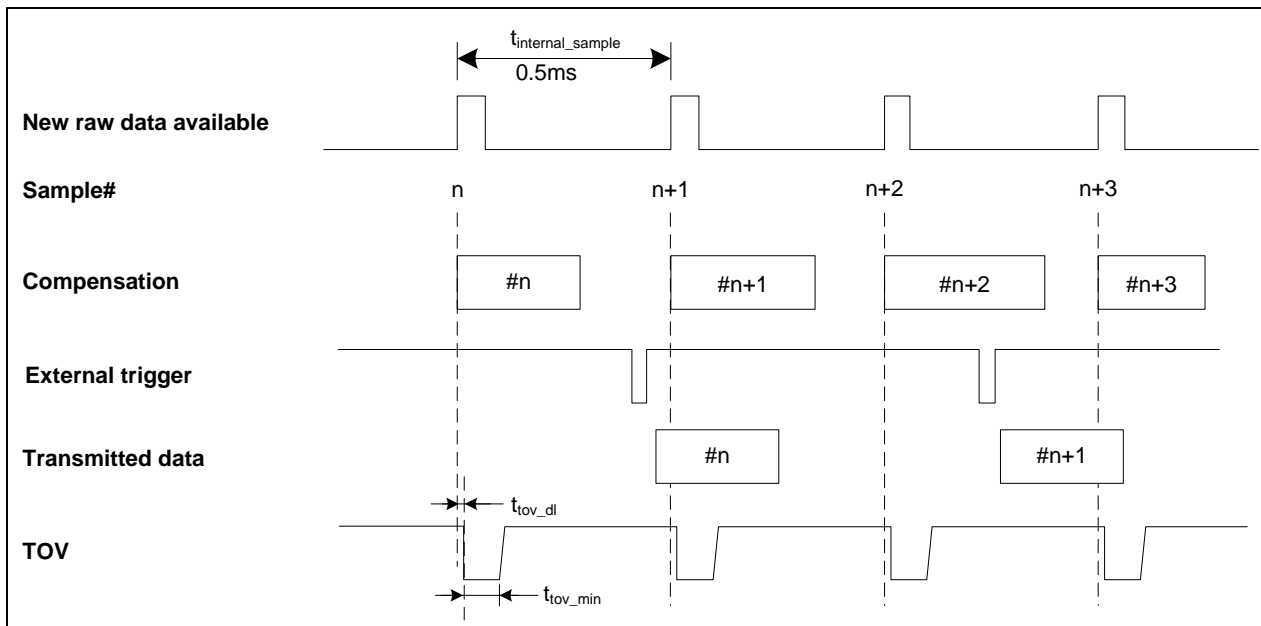

Figure 8-5: Timing of TOV with external trigger

8.4 Operating modes

The operating modes of STIM318 are shown in Figure 8-6:

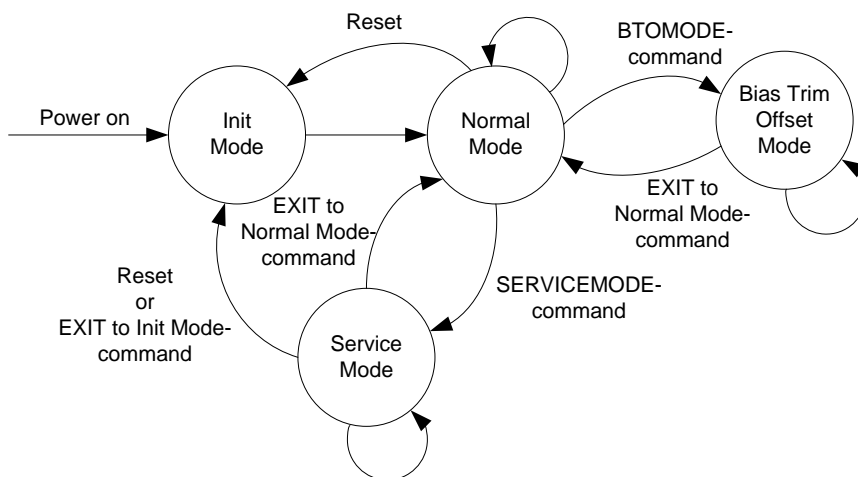

Figure 8-6: Operating modes

8.4.1 Init Mode

Init Mode is entered after the following conditions:

- power on
- after an external reset
- when receiving a reset-command in Normal Mode
- when exiting to Init Mode from Service Mode.

In Init Mode the system waits for internal references to settle, resets and synchronizes the sensor channels and transmits four special datagrams containing part number, serial number, configuration data and bias trim offsets. Note that length and format of the special datagrams are different to the datagrams in Normal Mode.

The content and format of the Part Number datagram is specified in Table 6-9.

The content and format of the Serial Number datagram is specified in Table 6-10.

The content and format of the Configuration datagram is specified in Table 6-11.

The content and format of the Bias Trim Offset datagram is specified in Table 6-12.

After having transmitted the special Part Number, Serial Number, Configuration and Bias Trim Offset datagrams, STIM318 enters Normal Mode.

All these special datagrams can also be requested by commands in Normal Mode, ref. section: 9.

8.4.2 Normal Mode

In Normal Mode STIM318 will constantly transmit sensor-data at the configured sample rate. The internal sample rate will always be at the maximum regardless of the transmitted sample rate.

STIM318 will continue to transmit data regardless of any errors reported in the STATUS-bytes (ref. Table 6-18). Hence the content of the STATUS-byte should continuously be examined.

The content of the Normal Mode datagram is specified in Table 6-15.

8.4.2.1 Start-Up

When STIM318 enters Normal Mode from Init Mode, there will be a start-up period where STIM318 is stabilizing the gyros. During this period bit 6 is set in the STATUS-byte (ref. Table 6-18) to communicate its condition. Once stabilized, bit 6 will be cleared. During this period the output data should be regarded as non-valid.

There will not be any start-up period when STIM318 is exiting from Service Mode directly to Normal Mode.

8.4.2.2 Data output options and interpretation

The gyros in STIM318 measure angular rate [°/s], the accelerometers measure acceleration [g] and the inclinometers measure acceleration [g]. However, in order to make the STIM318 more versatile, a few simple functions are offered, ref. Table 8-1 and Table 8-2:

Table 8-1: Implemented functions for gyro output units

Function	Description of function	Equation	Output unit
Incremental	Adds all internal samples between two transmissions multiplied by the time between internal samples	$Incremental = \sum_{i=1}^n AngularRate_i \cdot \frac{1}{2000} s$ $n = 2000 / \text{sample rate}$	[°]
Average	Calculates the average of the internal samples between two transmissions	$Average = \frac{1}{n} \cdot \sum_{i=1}^n AngularRate_i$ $n = 2000 / \text{sample rate}$	[°/s]
Integrated	Adds all internal samples multiplied by the time between internal samples since start-up / last reset. Note that the result takes values in the interval [-4°, 4°] and will naturally wrap-around with no error-message indication in the Status-byte	$Integrated = \sum_{i=1}^n AngularRate_i \cdot \frac{1}{2000} s$ $n = \text{internal samples (at a rate of 2000 samples/s) since start-up or last reset}$	[°]

Table 8-2: Implemented functions for accelerometer/inclinometer output units

Function	Description of function	Equation	Output unit
Incremental	Adds all internal samples between two transmissions multiplied by the time between internal samples and converted to [m/s]	$Incremental = k_0 \cdot \sum_{i=1}^n Acceleration_i \cdot \frac{1}{2000} s$ $k_0 = 9.80665 \text{ m/s}^2/\text{g}$ $n = 2000 / \text{sample rate}$	[m/s]
Average	Calculates the average of the internal samples between two transmissions	$Average = \frac{1}{n} \cdot \sum_{i=1}^n Acceleration_i$ $n = 2000 / \text{sample rate}$	[g]
Integrated	Adds all internal samples multiplied by the time between internal samples since start-up / last reset. Note that the result takes values in a specific interval as described in 8.4.2.2.10 and 8.4.2.2.14 for accelerometer and inclinometer respectively and will naturally wrap-around with no error-message indication in the Status-byte	$Integrated = k_0 \cdot \sum_{i=1}^n Acceleration_i \cdot \frac{1}{2000} s$ $k_0 = 9.80665 \text{ m/s}^2/\text{g}$ $n = \text{internal samples (at a rate of 2000 samples/s) since start-up or last reset}$	[m/s]

8.4.2.2.1 Delayed gyro output

The inherent group delay of the gyro-, accelerometer- and inclinometer-signals are different, ref. Table 6-3, Table 6-4 and Table 6-5 respectively.

An option is available to delay the gyro signals by 1.5ms in order for the group delay of gyros, and accelerometers to be similar. To enable this feature, select the gyro output-unit ≥ 8 , ref. section 10.7 and 13.

8.4.2.2.2 Gyro output unit = Angular Rate

In the case of STIM318 being configured to output angular rate, the equations for conversion to [°/s] can be found in Equation 1 and Figure 8-7. Note that the output data is represented as two's complement.

Equation 1: Converting output to [°/s]:

$$Output[^\circ/s] = \frac{(AR_1) \cdot 2^{16} + (AR_2) \cdot 2^8 + (AR_3)}{2^{14}}$$

where AR_1 is the most significant byte of the 24bit output
 AR_2 is the middle byte of the 24bit output
 AR_3 is the least significant byte of the 24bit output

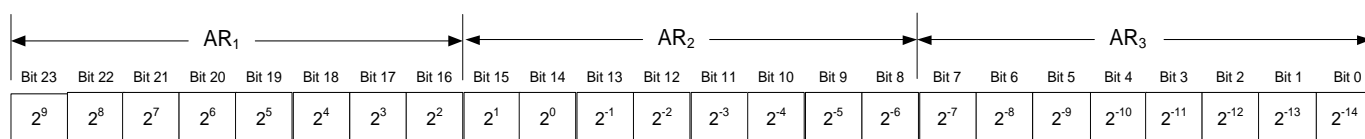

Figure 8-7: Converting output bytes to [°/s]

8.4.2.2.3 Gyro output unit = Incremental Angle

In the case of STIM318 being configured to output incremental angle per sample, the equations for conversion to [°/sample] can be found in Equation 2 and Figure 8-8. Note that the output data is represented as two's complement.

Equation 2: Converting output to [°/sample]

$$Output[^\circ/sample] = \frac{(IA_1) \cdot 2^{16} + (IA_2) \cdot 2^8 + (IA_3)}{2^{21}}$$

where IA_1 is the most significant byte of the 24bit output
 IA_2 is the middle byte of the 24bit output
 IA_3 is the least significant byte of the 24bit output

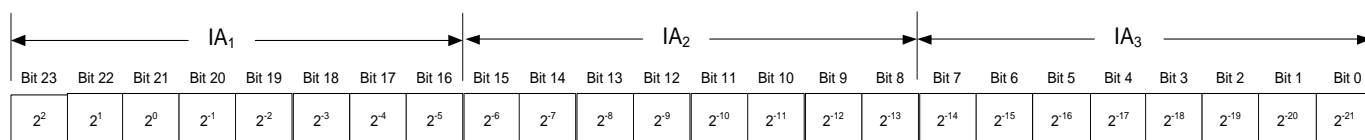

Figure 8-8: Converting output bytes to [°/sample]

8.4.2.2.4 Gyro output unit = Average Angular Rate

In the case of STIM318 being configured to output average angular rate, the transmitted data will be the average of the samples since last transmission. E.g. in the case of continuous transmission of datagrams and a sample rate of 500Hz, each transmission will contain the average of the four previous internal samples.

Note that the configured low-pass filtering is performed prior to calculating the average.

Conversion to [°/s] is the same as for angular rate and is described in Equation 1.

8.4.2.2.5 Gyro output unit = Integrated Angle

In the case of STIM318 being configured to output integrated angle, the transmitted data will be the continuously integrated angle since power-on or reset. The integrated angle will be in the interval [-4°, 4°] and will naturally wrap-around with no error-message indication in the Status-byte.

Conversion to [°] is the same as for incremental angle and is described in Equation 2.

8.4.2.2.6 Gyro g-compensation

As the STIM318 also contains accelerometers and inclinometers, functionality has been implemented to provide means to compensate for the g-sensitivity for gyro scale-factor and/or bias.

In addition, a simple 1-pole low-pass filter can be switched in to apply additional filtering of the accelerometer-/inclinometer-signal prior to use in the compensation, ref: Figure 8-10. A simplified compensation-scheme can be found in Figure 8-9.

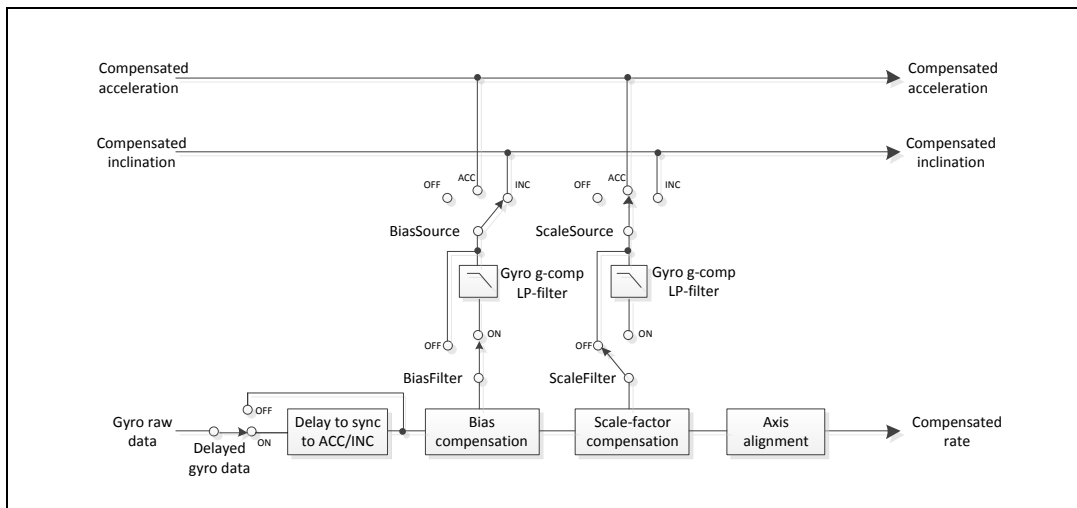

Figure 8-9: Simplified compensation-scheme for gyro g-compensation

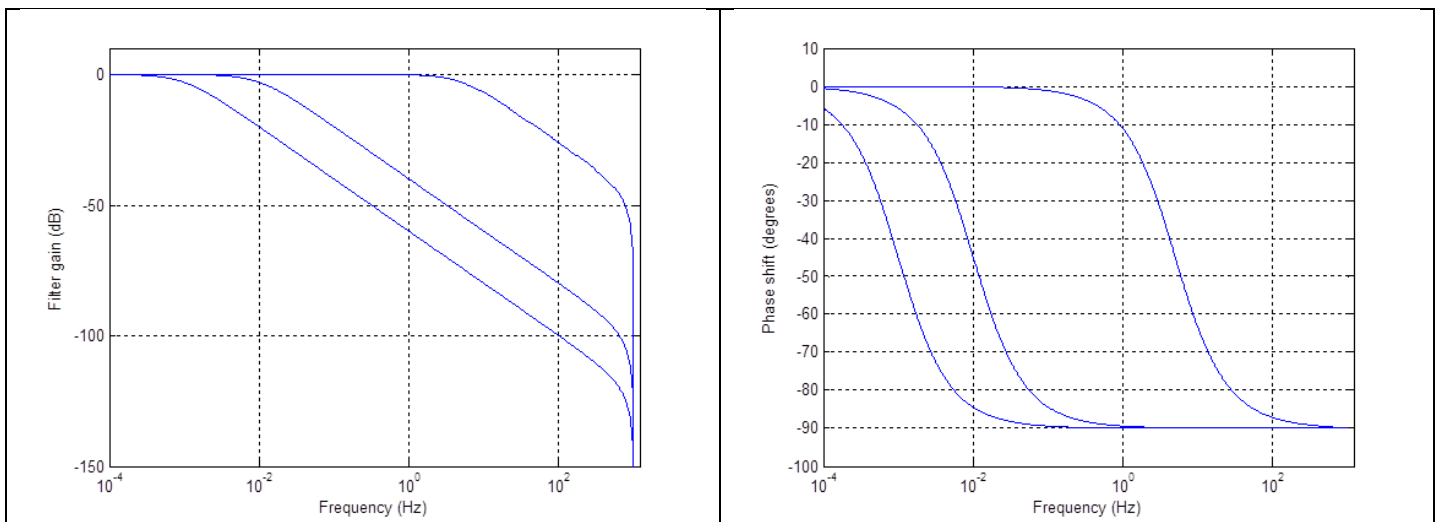

Figure 8-10: Frequency characteristics of g-compensation low-pass filter for 0.001Hz, 0.01Hz and 5Hz settings

8.4.2.2.7 Accelerometer output unit = Acceleration

In the case of STIM318 being configured to output acceleration, the equations for conversion to [g] can be found in Equation 3 and Figure 8-11. Note that the output data is represented as two's complement.

Equation 3: Converting output to [g]:

Range	Conversion:
10g	$Output[g] = \frac{(ACC_1) \cdot 2^{16} + (ACC_2) \cdot 2^8 + (ACC_3)}{2^{19}}$

where ACC_1 is the most significant byte of the 24bit output
 ACC_2 is the middle byte of the 24bit output
 ACC_3 is the least significant byte of the 24bit output

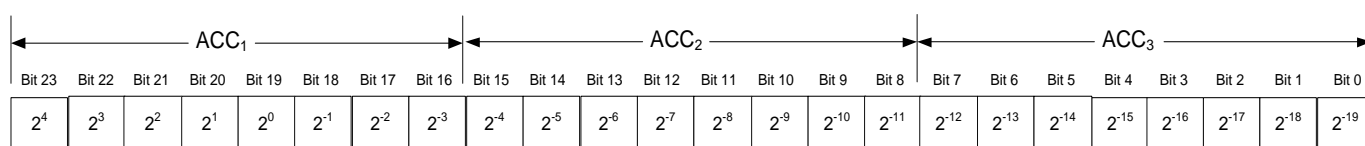

Figure 8-11: Converting output bytes to [g] (example is valid for 10g range)

8.4.2.2.8 Accelerometer output unit = Incremental Velocity

In the case of STIM318 being configured to output incremental velocity per sample, the equations for conversion to [m/s/sample] can be found in Equation 4 and Figure 8-12. Note that the output data is represented as two's complement.

Equation 4: Converting output to [m/s/sample]

Range	Conversion:
10g	$Output[m/s/sample] = \frac{(IV_1) \cdot 2^{16} + (IV_2) \cdot 2^8 + (IV_3)}{2^{22}}$

where IV_1 is the most significant byte of the 24bit output
 IV_2 is the middle byte of the 24bit output
 IV_3 is the least significant byte of the 24bit output

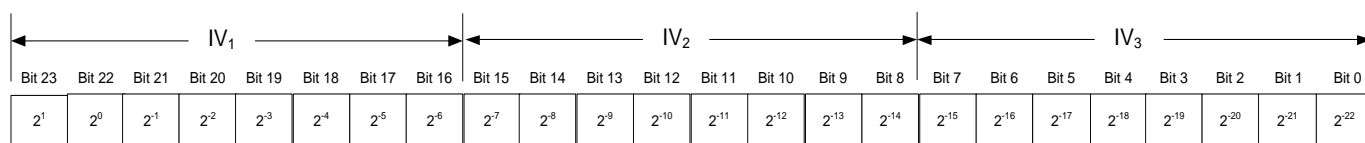

Figure 8-12: Converting output bytes to [m/s/sample] (example is valid for 10g range)

8.4.2.2.9 Accelerometer output unit = Average Acceleration

In the case of STIM318 being configured to output average acceleration, the transmitted data will be the average of the samples since last transmission. E.g. in the case of continuous transmission of datagrams and a sample rate of 500Hz, each transmission will contain the average of the four internal samples.

Conversion to [g] is the same as for angular rate and is described in Equation 3.

8.4.2.2.10 Accelerometer output unit = Integrated Velocity

In the case of STIM318 being configured to output integrated velocity, the transmitted data will be the continuously integrated velocity since power-on or reset. The integrated velocity will be in the interval as shown in Table 8-3 and will naturally wrap-around with no error-message indication in the Status-byte.

Table 8-3: Interval for integrated velocity

Range	Interval:
10g	[-2m/s, 2m/s>

Conversion to [m/s] is the same as for incremental velocity and is described in Equation 4.

8.4.2.2.11 Inclinometer output unit = Acceleration

In the case of STIM318 being configured to output acceleration, the equations for conversion to [g] can be found in Equation 5 and Figure 8-13. Note that the output data is represented as two's complement.

Equation 5: Converting output to [g]:

$$Output[g] = \frac{(ACC_1) \cdot 2^{16} + (ACC_2) \cdot 2^8 + (ACC_3)}{2^{22}}$$

where ACC_1 is the most significant byte of the 24bit output
 ACC_2 is the middle byte of the 24bit output
 ACC_3 is the least significant byte of the 24bit output

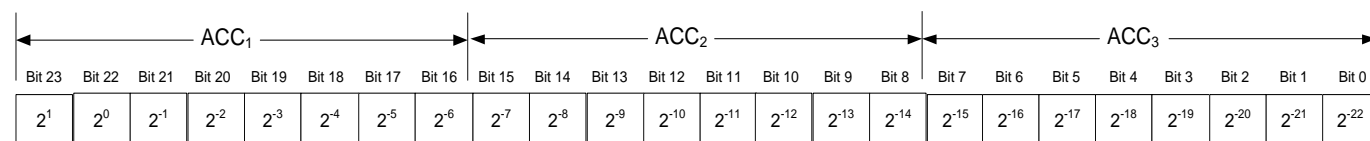

Figure 8-13: Converting output bytes to [g]

8.4.2.2.12 Inclinometer output unit = Incremental Velocity

In the case of STIM318 being configured to output incremental velocity per sample, the equations for conversion to [m/s/sample] can be found in Equation 6 and Figure 8-14. Note that the output data is represented as two's complement.

Equation 6: Converting output to [m/s/sample]

$$Output[m / s / sample] = \frac{(IV_1) \cdot 2^{16} + (IV_2) \cdot 2^8 + (IV_3)}{2^{25}}$$

where IV_1 is the most significant byte of the 24bit output
 IV_2 is the middle byte of the 24bit output
 IV_3 is the least significant byte of the 24bit output

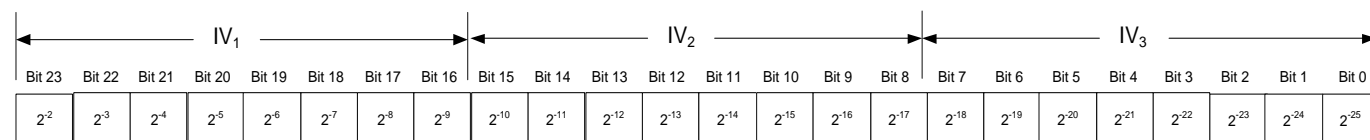

Figure 8-14: Converting output bytes to [m/s/sample]

8.4.2.2.13 Inclinometer output unit = Average Acceleration

In the case of STIM318 being configured to output average acceleration, the transmitted data will be the average of the samples since last transmission. E.g. in the case of continuous transmission of datagrams and a sample rate of 500Hz, each transmission will contain the average of the four internal samples.

Conversion to [g] is the same as for angular rate and is described in Equation 5.

8.4.2.2.14 Inclinometer output unit = Integrated Velocity

In the case of STIM318 being configured to output integrated velocity, the transmitted data will be the continuously integrated velocity since power-on or reset. The integrated velocity will be in the interval [0.25m/s, 0.25m/s> and will naturally wrap-around with no error-message indication in the Status-byte.

Conversion to [m/s] is the same as for incremental velocity and is described in Equation 6.

8.4.2.2.15 Temperature

Temperature data for each axis is available in certain datagrams (ref. section 13).

Equation 7 and Figure 8-15 show how to convert to [°C]. Note that the output data is represented as two's complement.

Equation 7: Converting temperature data to [°C]

$$Output[°C] = \frac{(T_1) \cdot 2^8 + (T_2)}{2^8}$$

where T_1 is the most significant byte of the 16bit output

T_2 is the least significant byte of the 16bit output

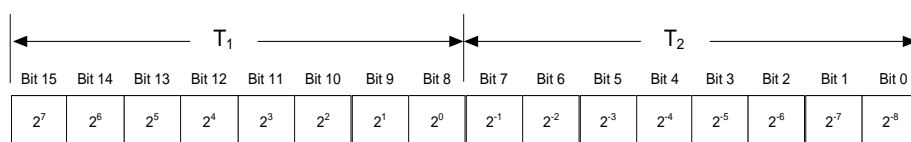

Figure 8-15: Converting temperature data to [°C]

8.4.2.2.16 Counter

Counter is continuously counting the internal samples (2000 samples/s). Counter is an un-signed single byte taking values in the interval [0 , 255]. The counter will naturally wrap-around with no error-message indication in the Status-byte.

8.4.2.2.17 Latency

To calculate the latency in [μs], refer to Equation 8 and Figure 8-16. Note that latency is an unsigned word.

Equation 8: Converting output to [μs]:

$$Output[\mu s] = (LT_1) \cdot 2^8 + (LT_2)$$

where LT_1 is the most significant byte of the 16bit output

LT_2 is the least significant byte of the 16bit output

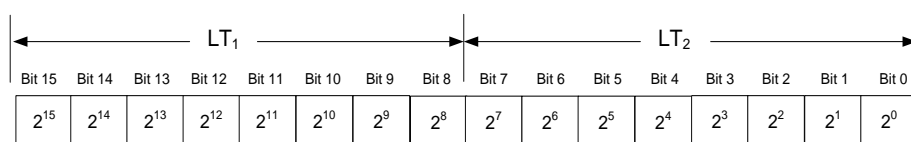

Figure 8-16: Converting output bytes to [μs]

8.4.2.3 Bias Trim Offset

The STIM318 offers the possibility to trim the biases by adding or subtracting user-defined offsets to the individual sensor signals. Adjusting the bias trim offsets can be done by entering Bias Trim Offset Mode (ref. section 8.4.4) or Service Mode (ref. section 10).

The bias trim offsets are applied to the sensor-signals after the compensation-algorithms with the sign-convention as shown in Equation 9:

Equation 9: Applying bias trim offsets:

$$Sensor_{adjusted} = Sensor_{compensated} + BiasTrimOffset$$

where $Sensor_{adjusted}$ is the sensor-data to be transmitted

$Sensor_{compensated}$ is the sensor-data after compensation

$BiasTrimOffset$ is the current bias trim offset for the particular sensor axis

Note that the bias trim offset is in [°/s] for the gyros and [g] for the accelerometers and inclinometers. This is also the case if the chosen output unit is incremental or integrated.

8.4.3 Service Mode

In Service Mode the communication interface is human readable and hence the communication format (ASCII) supports the use of terminal-based software during the development phase, when the configuration of a device needs to be changed or during investigations into an observed problem.

When Service Mode is entered, STIM318 will respond with its configuration information (same as the response to the `i` (INFORMATION) command, ref: Figure 10-1).

A set of commands are available, ref. Section 10, enabling the user to change intermediately or permanently the configuration parameters, display latest measurement results, display higher details on error information and perform a full diagnostic of the unit.

In Service Mode the gyro measurements will still be running in the background, enabling to switch directly back to Normal Mode without the need for any stabilization time of filters, etc. However the measurement data itself, when STIM318 is in Service Mode are not transmitted and therefore lost. By using the `a` (SINGLE-SHOT MEASUREMENT) command (ref. Section 10.2) it is possible to display single measurement results.

Exiting Service Mode can be done in several ways:

1. Using the external reset. This will force STIM318 into Init Mode. Be advised that during Init Mode, all the configuration parameters are loaded from flash. If any of the configuration parameters have been changed during the Service Mode session but not saved to flash, these changes will be overwritten by the content already stored in flash.
2. Using the `x` (EXIT) command. When using this command a parameter is required to decide whether the device should go to Init Mode or to Normal Mode. When exiting to Normal Mode, any of the changes made to the configuration parameters will still be valid. However, if not saved, the configuration parameters will be overwritten by the content already stored in flash at the next power-up or reset.

8.4.4 Bias Trim Offset Mode

In Bias Trim Offset Mode, the bias trim offsets can be adjusted.

After having received the "BTOMODE"-command (ref. section 9.8), STIM318 will stop transmitting Normal Mode datagrams and send an acknowledgement that it is now in Bias Trim Offset Mode (ref. section 11.1). Even though the Normal Mode datagrams are not transmitted, the measurements will continue in the background.

Several commands are available to adjust or reset the individual bias trim offsets, ref. section 11.

When the Bias Trim Offset Mode is exited, the STIM318 will return to Normal Mode and resume transmission of Normal Mode datagrams.

8.5 Self-diagnostics

STIM318 is continuously checking its internal status. The checks include:

- Check of internal references
- Check of sensors (error and overload)
- Check of internal temperatures
- Check of RAM and flash
- Check of supply voltage

A full diagnostic can be run to see the result of the individual checks by using the `c` (DIAGNOSTIC) command, ref. Section 10.3 in SERVICEMODE.

When an error situation is detected, the corresponding bit in the STATUS byte (ref. Table 6-18) will be set. If the sample-rate is set lower than 2000 samples/s, the STATUS byte will reflect the accumulated status of all the sub-samples between two data transmissions. The bits in the STATUS bytes are valid for the data in a single transmission and hence not latched.

Access to extended error registers containing accumulated error-information can be achieved either by using the Normal Mode-command "E" (EXTENDED ERROR INFORMATION DATAGRAM, ref. section 9.5 and Table 6-14) or the SERVICEMODE-command `i_e` (INFORMATION on ACCUMULATED LAST ERRORS, ref. section 10.1).

The extended error registers are cleared at the following events:

- After the start-up phase, triggered by power-on or reset
- After transmission of Extended Error Information Datagram (ref. section 9.5)
- After use of SERVICEMODE-command "i e" (INFORMATION on ACCUMULATED LAST ERRORS, ref. section 10.1)

9 COMMANDS IN NORMAL MODE

Several commands are available in Normal Mode, as listed in Table 9-1. Note that all commands in Normal Mode must be transmitted in upper case letters.

Table 9-1 Available commands in Normal Mode

Command	Short description
N	Transmits one Part Number datagram
I	Transmits one Serial Number datagram
C	Transmits one Configuration datagram
T	Transmits one Bias Trim Offset datagram
E	Transmits one Extended Error Information datagram
R	Resets the unit
SERVICEMODE	Enters Service Mode
BTOMODE	Enters Bias Trim Offset Mode

Table 9-2 List of special ASCII characters used in Normal Mode

Char	Hex	Dec	Short description
<CR>	0x0D	13	"Carriage Return": used as execution character for commands

No echo of received command characters or error messages will appear for these commands. Only at the receipt of the complete correct command, will STIM318 execute accordingly.

NB: if OUTPUT-UNIT is set to INCREMENTAL (ref. Section 10.7), the transmitted incremented value in the datagram following any of the requested special datagrams will NOT contain the incremental value since the last transmitted measurement. Hence the incremented value(s) occurring during the transmission of a special requested datagram will be lost.

9.1 N (PART NUMBER DATAGRAM) command

General description: Requests transmission of a Part Number datagram (ref. Table 6-9).

Table 9-3 : Available I (PART NUMBER DATAGRAM) command

Syntax	Response
N<CR>	Transmits one Part Number datagram

The Part Number datagram will replace the next transmitted Normal Mode datagram. If the Part Number datagram is longer than the chosen Normal Mode datagram, the Part Number datagram may replace more than one Normal Mode datagram transmission (dependent on sampling-rate and bit-rate).

If sample rate is set to external trigger, the Part Number datagram will be transmitted at the next external trigger input, replacing the datagram containing sensor data.

9.2 I (SERIAL NUMBER DATAGRAM) command

General description: Requests transmission of a Serial number datagram (ref. Table 6-10).

Table 9-4 : Available I (SERIAL NUMBER DATAGRAM) command

Syntax	Response
I<CR>	Transmits one Serial Number datagram

The Serial Number datagram will replace the next transmitted Normal Mode datagram. If the Serial Number datagram is longer than the chosen Normal Mode datagram, the Serial Number datagram may replace more than one Normal Mode datagram transmission (dependent on sampling-rate and bit-rate).

If sample rate is set to external trigger, the Serial Number datagram will be transmitted at the next external trigger input, replacing the datagram containing sensor data.

9.3 C (CONFIGURATION DATAGRAM) command

General description: Requests transmission of a Configuration datagram (ref. Table 6-11).

Table 9-5: Available C (CONFIGURATION DATAGRAM) command

Syntax	Response
C<CR>	Transmits one Configuration datagram

The Configuration datagram will replace the next transmitted Normal Mode datagram. If the Configuration datagram is longer than the chosen Normal Mode datagram, the Configuration datagram may replace more than one Normal Mode datagram transmission (dependent on sampling-rate and bit-rate).

If sample rate is set to external trigger, the Configuration datagram will be transmitted at the next external trigger input, replacing the datagram containing sensor data.

9.4 T (BIAS TRIM OFFSET DATAGRAM) command

General description: Requests transmission of a Bias Trim Offset datagram (ref. Table 6-12).

Table 9-6: Available B (BIAS TRIM OFFSET DATAGRAM) command

Syntax	Response
T<CR>	Transmits one Bias Trim Offset datagram

The Bias Trim Offset datagram will replace the next transmitted Normal Mode datagram. If the Bias Trim Offset datagram is longer than the chosen Normal Mode datagram, the Configuration datagram may replace more than one Normal Mode datagram transmission (dependent on sampling-rate and bit-rate).

If sample rate is set to external trigger, the Bias Trim Offset datagram will be transmitted at the next external trigger input, replacing the datagram containing sensor data.

9.5 E (EXTENDED ERROR INFORMATION DATAGRAM) command

General description: Requests transmission of an Extended Error Information datagram (ref. Table 6-13). This datagram contains the accumulated detected errors (ref. section 8.5).

Once the Extended Error Information datagram has been transmitted, the error-registers are cleared.

Table 9-7: Available E (EXTENDED ERROR INFORMATION) command

Syntax	Response
E<CR>	Transmits one Extended Error Information datagram

The Extended Error Information datagram will replace the next transmitted Normal Mode datagram. If the Extended Error Information datagram is longer than the chosen Normal Mode datagram, the Extended Error Information datagram may replace more than one Normal Mode datagram transmission (dependent on sampling-rate and bit-rate).

If sample rate is set to external trigger, the Extended Error Information datagram will be transmitted at the next external trigger input, replacing the datagram containing sensor data.

9.6 R (RESET) command

General description: Force a Reset

Table 9-8: Available R (RESET) command

Syntax	Response
R<CR>	Resets the unit

9.7 SERVICEMODE command

General description: Enters Service Mode (ref. section 8.4.2.3).

Table 9-9: Available SERVICEMODE command

Syntax	Response
SERVICEMODE<CR>	Enters Service Mode

If the command is received during the transmission of a datagram, it will complete the transmission before entering Service Mode.

When entering Service Mode, the configuration and identification data of the device will be listed, as shown in Figure 9-1:

```

SERIAL NUMBER = N25580846002002
PRODUCT = STIM318
PART NUMBER = 84192-440000-321 REV -
FW CONFIG = SWD12270 REV 0
GYRO OUTPUT UNIT = [°/s] – ANGULAR RATE DELAYED
ACCELEROMETER OUTPUT UNIT = [g] – ACCELERATION
INCLINOMETER OUTPUT UNIT = [g] - ACCELERATION
SAMPLE RATE [samples/s] = 2000
GYRO CONFIG = XYZ
ACCELEROMETER CONFIG = XYZ
INCLINOMETER CONFIG = XYZ
GYRO RANGE:
X-AXIS: ± 400°/s
Y-AXIS: ± 400°/s
Z-AXIS: ± 400°/s
ACCELEROMETER RANGE:
X-AXIS: ± 10g
Y-AXIS: ± 10g
Z-AXIS: ± 10g
INCLINOMETER RANGE:
X-AXIS: ± 1.7g
Y-AXIS: ± 1.7g
Z-AXIS: ± 1.7g
GYRO LP FILTER -3dB FREQUENCY, X-AXIS [Hz] = 262
GYRO LP FILTER -3dB FREQUENCY, Y-AXIS [Hz] = 262
GYRO LP FILTER -3dB FREQUENCY, Z-AXIS [Hz] = 262
ACCELEROMETER LP FILTER -3dB FREQUENCY, X-AXIS [Hz] = 262
ACCELEROMETER LP FILTER -3dB FREQUENCY, Y-AXIS [Hz] = 262
ACCELEROMETER LP FILTER -3dB FREQUENCY, Z-AXIS [Hz] = 262
INCLINOMETER LP FILTER -3dB FREQUENCY, X-AXIS [Hz] = 262
INCLINOMETER LP FILTER -3dB FREQUENCY, Y-AXIS [Hz] = 262
INCLINOMETER LP FILTER -3dB FREQUENCY, Z-AXIS [Hz] = 262
GYRO G-COMPENSATION:
BIAS SOURCE, X-AXIS = OFF
BIAS G-COMP LP-FILTER, X-AXIS = NA
SCALE SOURCE, X-AXIS = ACC
SCALE G-COMP LP-FILTER, X-AXIS = OFF
BIAS SOURCE, Y-AXIS = OFF
BIAS G-COMP LP-FILTER, Y-AXIS = NA
SCALE SOURCE, Y-AXIS = ACC
SCALE G-COMP LP-FILTER, Y-AXIS = OFF
BIAS SOURCE, Z-AXIS = OFF
BIAS G-COMP LP-FILTER, Z-AXIS = NA
SCALE SOURCE, Z-AXIS = ACC
SCALE G-COMP LP-FILTER, Z-AXIS = OFF
G-COMP LP-FILTER CUTOFF = 0.010 HZ
BIAS TRIM OFFSET:
GYRO X-AXIS [°/s] = 0.02343
GYRO Y-AXIS [°/s] = -0.01222
GYRO Z-AXIS [°/s] = 0.00111
ACCELEROMETER X-AXIS [g] = -0.004256
    
```

```

ACCELEROMETER Y-AXIS [g ] = -0.013777
ACCELEROMETER Z-AXIS [g ] = 0.000111
INCLINOMETER X-AXIS [g ] = 0.0034256
INCLINOMETER Y-AXIS [g ] = 0.0127598
INCLINOMETER Z-AXIS [g ] = - 0.0005309
REFERENCE INFO = 43639
DATAGRAM = RATE, ACCELERATION, INCLINATION
DATAGRAM TERMINATION = NONE
BIT-RATE [bits/s] = 921600
DATA LENGTH = 8
STOP BITS = 1
PARITY = NONE
LINE TERMINATION = ON
>

```

Figure 9-1: Example of response from SERVICEMODE command

9.8 BTOMODE command

General description: Enters Bias Trim Offset Mode allowing the user to adjust bias trim offsets (ref. section 8.4.4).

Table 9-10: Available BTOMODE command

Syntax	Response
BTOMODE<CR>	Enters Bias Trim Offset Mode to receive new adjustments to bias trim offsets

If the command is received during the transmission of a datagram, it will complete the transmission before entering Bias Trim Offset Mode.

10 COMMANDS IN SERVICE MODE

Several commands are available in Service Mode, as listed in Table 10-1. Note that all commands in Service Mode are case-sensitive (commands are lower case letters, whilst some parameters may be capital case letters).

Table 10-1 Available commands in Service Mode

Command	Short description
i	Lists specific information (e.g. serial number, configuration, error information)
a	Performs a single-shot measurement
c	Performs a diagnostic of the unit
d	Changes datagram format
t	Changes transmission parameters (e.g. bit-rate, data-length, stop-bits)
r	Turns line termination ON or OFF
u	Changes measurement output unit
f	Changes LP filter -3dB frequency
m	Changes sample rate
g	Changes the gyro g-compensation configuration for bias and scale factor
b	Changes bias trim offsets
s	Saves configuration data
x	Exits Service Mode and returns to Normal Mode or Init Mode
z	Restore to factory settings
?	Help function on the available commands in Service Mode

Table 10-2 List of special ASCII characters used in Service Mode

Char	Hex	Dec	Short description
<BS>	0x08	8	"Back Space": deletes last received character (received since last <CR>)
<CR>	0x0D	13	"Carriage Return": typically used as execution character for commands
<SP>	0x20	32	"Space": used to separate command and first parameter
,	0x2C	44	"Comma": used to separate parameters in a command
'>'	0x3E	62	Used together with <CR> as: "Ready to receive new command"-prompt

When STIM318 is in Service Mode and ready to receive a new command, it will issue the special ASCII character <CR> followed by '>'. As some commands (e.g. SINGLE-SHOT MEASUREMENT-command) may respond with a varying number of lines, automated set-ups should look for the special prompt-sequence (<CR>+'>') before issuing a new command.

Received characters will be echoed. A command is decoded and executed when receiving the special ASCII character <CR>. <BS> ("back-space") is also recognised and will delete the last received character in the input buffer. The size of the input buffer is 80 characters. <BS> is valid for the characters received since last <CR>.

The command-character and first parameter (when applicable) are separated by a space (character 0x20). When there are more than one parameter to a command (e.g. TRANSMISSION PARAMETER-command), these must be separated by a comma (character 0x2C).

In the event of an unknown command, inconsistent syntax or incorrect value of parameter(s), STIM318 will respond with an error message. Error messages are on the format:

E<nnn><SP><Error description><CR>

where nnn is an error number

10.1 i (INFORMATION) command

General description: Lists various requested information about the device

Table 10-3 : Available i (INFORMATION) commands

Syntax	Response
i<CR>	Lists the product configuration and identification data
i<SP><cmd><CR>	Gives information about the specific parameter

Table 10-4 : Allowed values for <cmd> parameter for i (INFORMATION) commands

<cmd>	Result
s	Returns the serial number of the device
n	Returns the product name of the device
x	Returns the part number of the device
a	Returns the axis configuration of the device
p	Returns the FW configuration and revision of the device
m	Returns the sample rate of the device
f	Returns the LP filter -3dB frequency for each axis
d	Returns the datagram format
t	Returns the transmission parameters of the device
r	Returns the line termination (ON or OFF)
u	Returns the output units of the device
g	Returns the configuration of the gyro g-compensation
b	Returns the bias trim offsets
e	Prints the extended error information from the accumulated detected error(s) since last error read-out in Service Mode or by the E-command in Normal Mode (ref. section 9.5)

Table 10-5: Error messages for i (INFORMATION) commands

Error	Message	Possible reason
E001	UNKOWN COMMAND	Command or parameter is not recognised
E002	INCORRECT NUMBER OF PARAMETERS	Too many or too few parameters, use of comma between command and first parameter
E003	INVALID PARAMETER	Value of parameter outside valid range

```
>i
SERIAL NUMBER = N25580846002002
PRODUCT = STIM318
PART NUMBER = 84192-440000-321 REV -
FW CONFIG = SWD12270 REV 0
GYRO OUTPUT UNIT = [°/s] – ANGULAR RATE DELAYED
ACCELEROMETER OUTPUT UNIT = [g] – ACCELERATION
INCLINOMETER OUTPUT UNIT = [g] - ACCELERATION
SAMPLE RATE [samples/s] = 2000
GYRO CONFIG = XYZ
ACCELEROMETER CONFIG = XYZ
INCLINOMETER CONFIG = XYZ
GYRO RANGE:
  X-AXIS: ± 400°/s
  Y-AXIS: ± 400°/s
  Z-AXIS: ± 400°/s
ACCELEROMETER RANGE:
  X-AXIS: ± 10g
  Y-AXIS: ± 10g
  Z-AXIS: ± 10g
INCLINOMETER RANGE:
  X-AXIS: ± 1.7g
  Y-AXIS: ± 1.7g
  Z-AXIS: ± 1.7g
GYRO LP FILTER -3dB FREQUENCY, X-AXIS [Hz] = 262
GYRO LP FILTER -3dB FREQUENCY, Y-AXIS [Hz] = 262
GYRO LP FILTER -3dB FREQUENCY, Z-AXIS [Hz] = 262
ACCELEROMETER LP FILTER -3dB FREQUENCY, X-AXIS [Hz] = 262
ACCELEROMETER LP FILTER -3dB FREQUENCY, Y-AXIS [Hz] = 262
ACCELEROMETER LP FILTER -3dB FREQUENCY, Z-AXIS [Hz] = 262
INCLINOMETER LP FILTER -3dB FREQUENCY, X-AXIS [Hz] = 262
INCLINOMETER LP FILTER -3dB FREQUENCY, Y-AXIS [Hz] = 262
INCLINOMETER LP FILTER -3dB FREQUENCY, Z-AXIS [Hz] = 262
GYRO G-COMPENSATION:
  BIAS SOURCE, X-AXIS = OFF
  BIAS G-COMP LP-FILTER, X-AXIS = NA
  SCALE SOURCE, X-AXIS = ACC
  SCALE G-COMP LP-FILTER, X-AXIS = OFF
  BIAS SOURCE, Y-AXIS = OFF
  BIAS G-COMP LP-FILTER, Y-AXIS = NA
  SCALE SOURCE, Y-AXIS = ACC
  SCALE G-COMP LP-FILTER, Y-AXIS = OFF
  BIAS SOURCE, Z-AXIS = OFF
  BIAS G-COMP LP-FILTER, Z-AXIS = NA
  SCALE SOURCE, Z-AXIS = ACC
  SCALE G-COMP LP-FILTER, Z-AXIS = OFF
  G-COMP LP-FILTER CUTOFF = 0.010 HZ
BIAS TRIM OFFSET:
  GYRO X-AXIS [°/s] = 0.02343
  GYRO Y-AXIS [°/s] = -0.01222
  GYRO Z-AXIS [°/s] = 0.00111
  ACCELEROMETER X-AXIS [g] = -0.004256
  ACCELEROMETER Y-AXIS [g] = -0.013777
  ACCELEROMETER Z-AXIS [g] = 0.000111
  INCLINOMETER X-AXIS [g] = 0.0034256
  INCLINOMETER Y-AXIS [g] = 0.0127598
  INCLINOMETER Z-AXIS [g] = - 0.0005309
  REFERENCE INFO = 43639
DATAGRAM = RATE, ACCELERATION, INCLINATION
DATAGRAM TERMINATION = NONE
BIT-RATE [bits/s] = 921600
DATA LENGTH = 8
STOP BITS = 1
PARITY = NONE
```

```
LINE TERMINATION = ON
```

```
>
```

Figure 10-1: Example of response from i (INFORMATION) command

```
>i s
```

```
SERIAL NUMBER = N25580846002002
```

```
>
```

Figure 10-2: Example of response from i s (INFORMATION on SERIAL NUMBER) command

```
>i n
```

```
PRODUCT = STIM318
```

```
>
```

Figure 10-3: Example of response from i n (INFORMATION on PRODUCT NAME) command

```
>i x
```

```
PART NUMBER = 84192-440000-321 REV -
```

```
>
```

Figure 10-4: Example of response from i x (INFORMATION on PART NUMBER) command

```
>i a
```

```
GYRO CONFIG = XYZ
```

```
ACCELEROMETER CONFIG = XYZ
```

```
INCLINOMETER CONFIG = XYZ
```

```
GYRO RANGE:
```

```
X-AXIS: ± 400°/s
```

```
Y-AXIS: ± 400°/s
```

```
Z-AXIS: ± 400°/s
```

```
ACCELEROMETER RANGE:
```

```
X-AXIS: ± 10g
```

```
Y-AXIS: ± 10g
```

```
Z-AXIS: ± 10g
```

```
INCLINOMETER RANGE:
```

```
X-AXIS: ± 1.7g
```

```
Y-AXIS: ± 1.7g
```

```
Z-AXIS: ± 1.7g
```

```
>
```

Figure 10-5: Example of response from i a (INFORMATION on AXIS CONFIGURATION) command

```
>i p
```

```
FW CONFIG = SWD12270 REV 0
```

```
>
```

Figure 10-6: Example of response from i p (INFORMATION on FW CONFIGURATION) command

```
>i m
```

```
SAMPLE RATE [samples/s] = 2000
```

```
>
```

Figure 10-7: Example of response from i m (INFORMATION on SAMPLE RATE) command

```
>i f
GYRO LP FILTER -3dB FREQUENCY, X-AXIS [Hz] = 262
GYRO LP FILTER -3dB FREQUENCY, Y-AXIS [Hz] = 262
GYRO LP FILTER -3dB FREQUENCY, Z-AXIS [Hz] = 262
ACCELEROMETER LP FILTER -3dB FREQUENCY, X-AXIS [Hz] = 262
ACCELEROMETER LP FILTER -3dB FREQUENCY, Y-AXIS [Hz] = 262
ACCELEROMETER LP FILTER -3dB FREQUENCY, Z-AXIS [Hz] = 262
INCLINOMETER LP FILTER -3dB FREQUENCY, X-AXIS [Hz] = 262
INCLINOMETER LP FILTER -3dB FREQUENCY, Y-AXIS [Hz] = 262
INCLINOMETER LP FILTER -3dB FREQUENCY, Z-AXIS [Hz] = 262
>
```

Figure 10-8: Example of response from i f (INFORMATION on LP FILTER -3dB FREQUENCY) command

```
>i d
DATAGRAM = RATE, ACCELERATION, INCLINATION
DATAGRAM TERMINATION = NONE
>
```

Figure 10-9: Example of response from i d (INFORMATION on DATAGRAM TRANSMISSION MODE AND TERMINATION) command

```
>i t
BIT-RATE [bits/s] = 921600
DATA LENGTH = 8
STOP BITS = 1
PARITY = NONE
>
```

Figure 10-10: Example of response from i t (INFORMATION on TRANSMISSION PARAMETERS) command

```
>i r
LINE TERMINATION = ON
>
```

Figure 10-11: Example of response from i r (INFORMATION on LINE TERMINATION) command

```
>i u
GYRO OUTPUT UNIT = [°/s] – ANGULAR RATE DELAYED
ACCELEROMETER OUTPUT UNIT = [g] – ACCELERATION
INCLINOMETER OUTPUT UNIT = [g] – ACCELERATION
>
```

Figure 10-12: Example of response from i u (INFORMATION on OUTPUT UNIT) command

```

>i g
GYRO G-COMPENSATION:
BIAS SOURCE, X-AXIS = OFF
BIAS G-COMP LP-FILTER, X-AXIS = NA
SCALE SOURCE, X-AXIS = ACC
SCALE G-COMP LP-FILTER, X-AXIS = OFF
BIAS SOURCE, Y-AXIS = OFF
BIAS G-COMP LP-FILTER, Y-AXIS = NA
SCALE SOURCE, Y-AXIS = ACC
SCALE G-COMP LP-FILTER, Y-AXIS = OFF
BIAS SOURCE, Z-AXIS = OFF
BIAS G-COMP LP-FILTER, Z-AXIS = NA
SCALE SOURCE, Z-AXIS = ACC
SCALE G-COMP LP-FILTER, Z-AXIS = OFF
G-COMP LP-FILTER CUTOFF = 0.010 HZ
>

```

Figure 10-13: Example of response from i g (INFORMATION on GYRO G-COMP) command

```

>i b
BIAS TRIM OFFSET:
GYRO X-AXIS [°/s ] = 0.02343
GYRO Y-AXIS [°/s ] = -0.01222
GYRO Z-AXIS [°/s ] = 0.00111
ACCELEROMETER X-AXIS [g ] = -0.004256
ACCELEROMETER Y-AXIS [g ] = -0.013777
ACCELEROMETER Z-AXIS [g ] = 0.000111
INCLINOMETER X-AXIS [g ] = 0.0034256
INCLINOMETER Y-AXIS [g ] = 0.0127598
INCLINOMETER Z-AXIS [g ] = - 0.0005309
REFERENCE INFO = 43639
>

```

Figure 10-14: Example of response from i b (INFORMATION on BIAS TRIM OFFSET) command

```

>i e
GYRO Z-AXIS NO CLIPPING DETECTED = FAIL

LAST ERROR HISTORY IS NOW CLEARED
>

```

Figure 10-15: Example of response from i e (INFORMATION on ACCUMULATED LAST ERRORS) command

```

>i e
NO ERRORS DETECTED
>

```

Figure 10-16: Example of response from i e (INFORMATION on ACCUMULATED LAST ERRORS) command

10.2 a (SINGLE-SHOT MEASUREMENT) command

General description: Displays the result of latest measurement (measurement process running constantly in the background).

NB: SINGLE-SHOT MEASUREMENT-command is not available if SAMPLE RATE is set to External Trigger.

Table 10-6: Available a (SINGLE-SHOT MEASUREMENT) command

Syntax	Response
a<CR>	Displays the result of the latest measurement <u>s</u> ample

Table 10-7: Error messages for a (SINGLE-SHOT MEASUREMENT) command

Error	Message	Possible reason
E001	UNKOWN COMMAND	Command is incorrectly entered
E002	INCORRECT NUMBER OF PARAMETERS	Any characters between command and <CR>

```

>a
GYRO X-AXIS = 1.43253 °/s
GYRO Y-AXIS = 2.34525 °/s
GYRO Z-AXIS = 243.33628 °/s
GYRO STATUS = 00000000 = OK

ACCELEROMETER X-AXIS = 0.042113 g
ACCELEROMETER Y-AXIS = 0.000342 g
ACCELEROMETER Z-AXIS = 0.929376 g
ACCELEROMETER STATUS = 00000000 = OK

INCLINOMETER X-AXIS = 0.0426473 g
INCLINOMETER Y-AXIS = 0.0003832 g
INCLINOMETER Z-AXIS = 0.9246325 g
INCLINOMETER STATUS = 00000000 = OK

TEMPERATURE GYRO X-AXIS = 32.326 °C
TEMPERATURE GYRO Y-AXIS = 32.467 °C
TEMPERATURE GYRO Z-AXIS = 32.265 °C
TEMPERATURE STATUS = 00000000 = OK

TEMPERATURE ACC X-AXIS = 32.846 °C
TEMPERATURE ACC Y-AXIS = 32.477 °C
TEMPERATURE ACC Z-AXIS = 32.965 °C
TEMPERATURE STATUS = 00000000 = OK

TEMPERATURE INC X-AXIS = 32.326 °C
TEMPERATURE INC Y-AXIS = 32.123 °C
TEMPERATURE INC Z-AXIS = 32.326 °C
TEMPERATURE STATUS = 00000000 = OK

COUNTER = 10
LATENCY = 516 us

>

```

Figure 10-17: Example of response from a (SINGLE-SHOT MEASUREMENT) command

```
>a
GYRO X-AXIS = 0.00071 °/s
GYRO Y-AXIS = 0.12324 °/s
GYRO Z-AXIS = 480.00000 °/s
GYRO STATUS = 00010100 = NOT OK
  BIT 4: OVERLOAD
  BIT 2: ERROR IN Z-CHANNEL

ACCELEROMETER X-AXIS = 0.042113 g
ACCELEROMETER Y-AXIS = 0.000342 g
ACCELEROMETER Z-AXIS = 0.929376 g
ACCELEROMETER STATUS = 00000000 = OK

INCLINOMETER X-AXIS = 0.0426473 g
INCLINOMETER Y-AXIS = 0.0003832 g
INCLINOMETER Z-AXIS = 0.9246325 g
INCLINOMETER STATUS = 00000000 = OK

TEMPERATURE GYRO X-AXIS = 32.326 °C
TEMPERATURE GYRO Y-AXIS = 32.467 °C
TEMPERATURE GYRO Z-AXIS = 32.265 °C
TEMPERATURE STATUS = 00000000 = OK

TEMPERATURE ACC X-AXIS = 32.846 °C
TEMPERATURE ACC Y-AXIS = 32.477 °C
TEMPERATURE ACC Z-AXIS = 32.965 °C
TEMPERATURE STATUS = 00000000 = OK

TEMPERATURE INC X-AXIS = 32.326 °C
TEMPERATURE INC Y-AXIS = 32.123 °C
TEMPERATURE INC Z-AXIS = 32.326 °C
TEMPERATURE STATUS = 00000000 = OK

COUNTER = 10
LATENCY = 516 us
>
```

Figure 10-18: Example of response from a (SINGLE-SHOT MEASUREMENT) command with error flagging

10.3 c (DIAGNOSTIC) command

General description: Performs a diagnostic of the unit.

Table 10-8: Available c (DIAGNOSTIC) command

Syntax	Response
c<CR>	Performs a diagnostic check

Table 10-9: Error messages for c (DIAGNOSTIC) command

Error	Message	Possible reason
E001	UNKOWN COMMAND	Command is incorrectly entered
E002	INCORRECT NUMBER OF PARAMETERS	Any characters between command and <CR>

```

SERIAL NUMBER = N25581142431021
PRODUCT = STIM318
PART NUMBER = 84192-440000-321 REV -
HW CONFIG = M5728 REV 9
FW CONFIG = SWD12270 REV 0
SYSTEM STATUS:
RAM CHECK = OK
FLASH CHECK = OK
STACK STATUS MONITOR = OK
STACK COMMAND HANDLER = OK
STACK SAMPLE = OK
STACK FLASH = OK
STACK TRANSMIT = OK
MICRO CONTROLLER TEMPERATURE = OK
START-UP PHASE = NOT ACTIVE
SELF-TEST RUNNING = OK
UART = OK
VOLTAGES AND REFERENCES:
REFERENCE VOLTAGE_1 = FAIL
REFERENCE VOLTAGE_2 = OK
REFERENCE VOLTAGE_3 = OK
REFERENCE VOLTAGE_4 = OK
REGULATED VOLTAGE_1 = OK
REGULATED VOLTAGE_2 = OK
REGULATED VOLTAGE_3 = OK
SUPPLY VOLTAGE 5.0V = OK
INTERNAL DAC = OK
GYRO X-AXIS:
GYRO X-AXIS DATA RECEIVED = OK
GYRO X-AXIS EXCITATION FREQUENCY = OK
GYRO X-AXIS ASIC TEMPERATURE = OK
GYRO X-AXIS TEMPERATURE = OK
GYRO X-AXIS NO CLIPPING DETECTED = OK
GYRO X-AXIS NO OVERLOAD DETECTED = OK
GYRO X-AXIS INTERNAL COMMUNICATION = OK
GYRO X-AXIS NO ASIC OVERFLOW DETECTED = OK
GYRO X-AXIS EXCITATION AMPLITUDE = OK
GYRO X-AXIS CONFIGURATION = OK
GYRO Y-AXIS:
GYRO Y-AXIS DATA RECEIVED = OK
GYRO Y-AXIS EXCITATION FREQUENCY = OK
GYRO Y-AXIS ASIC TEMPERATURE = OK
GYRO Y-AXIS TEMPERATURE = OK
GYRO Y-AXIS NO CLIPPING DETECTED = OK
GYRO Y-AXIS NO OVERLOAD DETECTED = OK
GYRO Y-AXIS INTERNAL COMMUNICATION = OK
GYRO Y-AXIS NO ASIC OVERFLOW DETECTED = OK
GYRO Y-AXIS EXCITATION AMPLITUDE = OK
GYRO Y-AXIS CONFIGURATION = OK
GYRO Z-AXIS:
GYRO Z-AXIS DATA RECEIVED = OK
GYRO Z-AXIS EXCITATION FREQUENCY = OK
GYRO Z-AXIS ASIC TEMPERATURE = OK
GYRO Z-AXIS TEMPERATURE = OK
GYRO Z-AXIS NO CLIPPING DETECTED = OK
GYRO Z-AXIS NO OVERLOAD DETECTED = OK
GYRO Z-AXIS INTERNAL COMMUNICATION = OK
GYRO Z-AXIS NO ASIC OVERFLOW DETECTED = OK
    
```

```
GYRO Z-AXIS EXCITATION AMPLITUDE = OK
GYRO Z-AXIS CONFIGURATION = OK
ACCELEROMETER X-AXIS:
ACCELEROMETER X-AXIS NO CLIPPING DETECTED = OK
ACCELEROMETER X-AXIS NO OVERLOAD DETECTED = OK
ACCELEROMETER X-AXIS TEMPERATURE = OK
ACCELEROMETER X-AXIS ADC = OK
ACCELEROMETER Y-AXIS:
ACCELEROMETER Y-AXIS NO CLIPPING DETECTED = OK
ACCELEROMETER Y-AXIS NO OVERLOAD DETECTED = OK
ACCELEROMETER Y-AXIS TEMPERATURE = OK
ACCELEROMETER Y-AXIS ADC = OK
ACCELEROMETER Z-AXIS:
ACCELEROMETER Z-AXIS NO CLIPPING DETECTED = OK
ACCELEROMETER Z-AXIS NO OVERLOAD DETECTED = OK
ACCELEROMETER Z-AXIS TEMPERATURE = OK
ACCELEROMETER Z-AXIS ADC = OK
INCLINOMETER X-AXIS:
INCLINOMETER X-AXIS NO CLIPPING DETECTED = OK
INCLINOMETER X-AXIS NO OVERLOAD DETECTED = OK
INCLINOMETER X-AXIS TEMPERATURE = OK
INCLINOMETER X-AXIS ADC = OK
INCLINOMETER Y-AXIS:
INCLINOMETER Y-AXIS NO CLIPPING DETECTED = OK
INCLINOMETER Y-AXIS NO OVERLOAD DETECTED = OK
INCLINOMETER Y-AXIS TEMPERATURE = OK
INCLINOMETER Y-AXIS ADC = OK
INCLINOMETER Z-AXIS:
INCLINOMETER Z-AXIS NO CLIPPING DETECTED = OK
INCLINOMETER Z-AXIS NO OVERLOAD DETECTED = OK
INCLINOMETER Z-AXIS TEMPERATURE = OK
INCLINOMETER Z-AXIS ADC = OK
```

>

Figure 10-19: Example of response from c (DIAGNOSTIC) command

10.4 d (DATAGRAM FORMAT) command

General description: Sets the datagram transmission mode and termination (ref. Table 6-7 and section 13).

Note that the datagram format could be considered invalid, even if it has been entered correctly. This is because a valid datagram format also depends on the chosen sample rate and bit rate (ref. Table 6-8 and error message E007 in Table 10-13).

Note that this change will only be effective until STIM318 is initialized, reset or powered off, unless the new setting has been stored in flash using the SAVE-command (ref. section 10.10). In order to use or test a new setting in Normal Mode without permanently storing it, this can be achieved by using the EXIT n-command (ref. section 10.13).

Table 10-10 : Available d (DATAGRAM FORMAT) command

Syntax	Response
d<SP><type>','<term><CR>	Changes the datagram transmission mode and termination in Normal Mode

Table 10-11 : Allowed values for <type> parameter of d (DATAGRAM TRANSMISSION MODE AND TERMINATION) command

<type>	Datagram content
0	ID, rate, counter, latency, CRC
1	ID, rate, acceleration, counter, latency, CRC
2	ID, rate, inclination, counter, latency, CRC
3	ID, rate, acceleration, inclination, counter, latency, CRC
4	ID, rate, temperature, counter, latency, CRC
5	ID, rate, acceleration, temperature, counter, latency, CRC
6	ID, rate, inclination, temperature, counter, latency, CRC
7	ID, rate, acceleration, inclination, temperature, counter, latency, CRC

Table 10-12 : Allowed values for <term> parameter of d (DATAGRAM TRANSMISSION MODE AND TERMINATION) command

<term>	Result
0	Changes the datagram termination to no termination
1	Changes the datagram termination to <CR><LF>

Table 10-13: Error messages for d (DATAGRAM TRANSMISSION MODE AND TERMINATION) command

Error	Message	Possible reason
E001	UNKOWN COMMAND	Command is incorrectly entered
E002	INCORRECT NUMBER OF PARAMETERS	Too many or too few parameters, use of comma between command and first parameter
E003	INVALID PARAMETER	Value of parameter outside valid range
E007	DATAGRAM WILL BE TOO LONG TO TRANSMIT	Combination of bit-rate, sample rate and datagram content results in a datagram that cannot be transmitted

```
>d 4,0
DATAGRAM = RATE, TEMPERATURE
DATAGRAM TERMINATION = NONE
>
```

Figure 10-20: Example of response from d (DATAGRAM MODE AND TERMINATION) command

```
>d 3,1
DATAGRAM = RATE, ACCELERATION, INCLINATION
DATAGRAM TERMINATION = <CR><LF>
>
```

Figure 10-21: Example of response from d (DATATGRAM MODE AND TERMINATION) command

10.5 t (TRANSMISSION PARAMETERS) command

General description: Changes the transmission parameters for the RS422 interface.

Note that the bit-rate could be considered invalid, even if it has been entered correctly. This is because a valid bit-rate also depends on the sample rate and chosen datagram content (ref. Table 6-8 and error message E007 in Table 10-18).

Note that this change will only be effective until STIM318 is initialized, reset or powered off, unless the new setting has been stored in flash using the SAVE-command (ref. section 10.10). If confirmation to the SAVE-command is not "Y", the transmission parameters will be reset to the previously stored settings. In order to use or test a new setting in Normal Mode without permanently storing it, this can be achieved by using the EXIT n-command (ref. section 10.13).

Table 10-14 : Available t (TRANSMISSION PARAMETERS) commands

Syntax	Response
t<SP><bit-rate code><CR>	Changes the transmission bit-rate and leaves number of stop-bits and parity unchanged
t<SP><bit-rate code>','<stop-bits>','<parity><CR>	Changes the transmission bit-rate, number of stop-bits and parity
t<SP>'f','<bit-rate><CR>	Changes the transmission bit-rate to a user-defined bit-rate and leaves number of stop-bits and parity unchanged, ref. section 10.5.1
t<SP>'f','<bit-rate>','<stop-bits>','<parity><CR>	Changes the transmission bit-rate to a user-defined bit-rate, number of stop-bits and parity, ref. section 10.5.1

Table 10-15: Allowed values for <bit-rate code> parameter for t (TRANSMISSION PARAMETERS) commands

<bit-rate code>	Result
0	Will set the bit-rate to 377400 bits/s
1	Will set the bit-rate to 460800 bits/s
2	Will set the bit-rate to 921600 bits/s
3	Will set the bit-rate to 1843200 bits/s

Table 10-16: Allowed values for <stop-bits> parameter for t (TRANSMISSION PARAMETERS) commands

<stop-bits>	Result
1	Will set number of stop bits to 1
2	Will set number of stop bits to 2

Table 10-17: Allowed values for <parity> parameter for t (TRANSMISSION PARAMETERS) commands

<parity>	Result
0	Will set no parity
1	Will set odd parity
2	Will set even parity

10.5.1 User-defined bit-rate

The STIM318 hardware is capable of setting bit-rates in the range between 1500 and 5184000 bits/s. However, the sample rate and the datagram length decide the minimum bit-rate possible, ref. Equation 10:

Equation 10: Minimum bit-rate

$$Bit - rate_{MIN} = 1.1 \cdot bits \cdot bytes \cdot sample_rate$$

where bits = start-bit (1) + data-bits (8) + stop-bits (1 or 2) + parity-bit (0 or 1)
 bytes = number of bytes in the chosen datagram, ref. Table 6-15 and Table 6-8 (NB: number of bytes in Table 6-8 excludes <CR><LF>. If <CR><LF> termination has been chosen, ref. section 10.4 DATAGRAM FORMAT-command, the 2 additional bytes must be added)
 sample_rate is the chosen sample rate [samples/s]

If a bit-rate, lower than the allowed bit-rate defined by Equation 10, is entered, the command will respond with error message E007, ref. Table 10-18.

There are a finite number of bit-rates possible to set. This is defined in Equation 11:

Equation 11: Set bit-rate

$$\text{Bit-rate}_{SET} = \frac{82944000}{n} \text{ bits / s}$$

where n is an integer

The actually set bit-rate will hence be the closest to requested bit-rate. The response of the `t` (TRANSMISSION PARAMETERS)-command will be the set bit-rate. Be aware that for certain bit-rates above 1.5Mbit/s, the deviation between the requested bit-rate and set bit-rate could be larger than 1% and may be in conflict with the RS422 specification. No warnings are issued related to this issue. As a safety precaution, the new bit-rate can only be permanently set by using the `s` (SAVE)-command (using the new bit-rate).

Table 10-18: Error messages for `t` (TRANSMISSION PARAMETERS) commands

Error	Message	Possible reason
E001	UNKOWN COMMAND	Command is incorrectly entered
E002	INCORRECT NUMBER OF PARAMETERS	Too many or too few parameters, use of comma between command and first parameter
E003	INVALID PARAMETER	Value of parameter outside valid range
E007	DATAGRAM WILL BE TOO LONG TO TRANSMIT	Combination of bit-rate, sample rate and datagram content results in a datagram that cannot be transmitted

```
>t 2,1,2
BIT-RATE [bits/s] = 921600
DATA LENGTH = 8
STOP BITS = 1
PARITY = EVEN
>
```

Figure 10-22: Example of response from `t` (TRANSMISSION PARAMETERS) command to set standard bit-rate

```
>t f,500000
BIT-RATE [bits/s] = 500023
DATA LENGTH = 8
STOP BITS = 1
PARITY = EVEN
>
```

Figure 10-23: Example of response from `t` (TRANSMISSION PARAMETERS) command to set user-defined bit-rate

10.6 r (LINE TERMINATION) command

General description: Turns the line termination ON or OFF. Line termination should be ON when communicating point-point (single master – single slave).

Note that this change will only be effective until STIM318 is initialized, reset or powered off, unless the new setting has been stored in flash using the SAVE-command (ref. section 10.10). In order to use or test a new setting in Normal Mode without permanently storing it, this can be achieved by using the EXIT n-command (ref. section 10.13).

Table 10-19: Available r (LINE TERMINATION) command

Syntax	Response
r<SP><lineterm><CR>	Changes the line termination

Table 10-20: Allowed values for r (LINE TERMINATION) command

<lineterm>	Result
0	Turns line termination OFF
1	Turns line termination ON

Table 10-21: Error messages for r (LINE TERMINATION) command

Error	Message	Possible reason
E001	UNKOWN COMMAND	Command is incorrectly entered
E002	INCORRECT NUMBER OF PARAMETERS	Too many or too few parameters, use of comma between command and first parameter
E003	INVALID PARAMETER	Value of parameter outside valid range

```
>r 0
LINE TERMINATION = OFF
>
```

Figure 10-24: Example of response from r 0 (LINE TERMINATION) command

```
>r 1
LINE TERMINATION = ON
>
```

Figure 10-25: Example of response from r 1 (LINE TERMINATION) command

10.7 u (OUTPUT UNIT) command

General description: Sets the output unit of the transmission in Normal Mode.

Note that this change will only be effective until STIM318 is initialized, reset or powered off, unless the new setting has been stored in flash using the SAVE-command (ref. section 10.10). In order to use or test a new setting in Normal Mode without permanently storing it, this can be achieved by using the EXIT n-command (ref. section 10.13).

Table 10-22: Available u (OUTPUT UNIT) command

Syntax	Response
u<SP>'<sens>',<unit><CR>	Changes the unit of the transmission in Normal Mode

Table 10-23: Allowed values for <sens> and <unit> for u (OUTPUT UNIT) command

<sens>	<unit>	Result
g	0	Changes the gyro output unit to angular rate [°/s]
g	1	Changes the gyro output unit to incremental angle [°/sample]
g	2	Changes the gyro output unit to average angular rate [°/s]
g	3	Changes the gyro output unit to integrated angle [°]
g	8	Changes the gyro output unit to angular rate – delayed [°/s]
g	9	Changes the gyro output unit to incremental angle – delayed [°/sample]
g	a	Changes the gyro output unit to average angular rate – delayed [°/s]
g	b	Changes the gyro output unit to integrated angle – delayed [°]
a	0	Changes the accelerometer output unit to acceleration [g]
a	1	Changes the accelerometer output unit to incremental velocity [m/s/sample]
a	2	Changes the accelerometer output unit to average acceleration [g]
a	3	Changes the accelerometer output unit to integrated velocity [m/s]
i	0	Changes the inclinometer output unit to acceleration [g]
i	1	Changes the inclinometer output unit to incremental velocity [m/s/sample]
i	2	Changes the inclinometer output unit to average acceleration [g]
i	3	Changes the inclinometer output unit to integrated velocity [m/s]

Table 10-24: Error messages for u (OUTPUT UNIT) command

Error	Message	Possible reason
E001	UNKOWN COMMAND	Command is incorrectly entered
E002	INCORRECT NUMBER OF PARAMETERS	Too many or too few parameters, use of comma between command and first parameter
E003	INVALID PARAMETER	Value of parameter outside valid range

```
>u g,0
GYRO OUTPUT UNIT = [°/s] – ANGULAR RATE
>
```

Figure 10-26: Example of response from u (OUTPUT UNIT) command

```
>u a,2
ACCELEROMETER OUTPUT UNIT = [g] – AVERAGE ACCELERATION
>
```

Figure 10-27: Example of response from u (OUTPUT UNIT) command

10.8 f (LP FILTER -3dB FREQUENCY) command

General description: Changes the low-pass filter -3dB frequency for one or all axes.

Note that low pass filter settings should be considered together with sample rate in order to avoid issues with folding due to undersampling. No warnings will be issued by STIM318 if e.g. a high filter bandwidth and a low sample rate have been chosen.

Note that change in filter setting will change the group delay, ref. Table 6-7.

Note that this change will only be effective until STIM318 is initialized, reset or powered off, unless the new setting has been stored in flash using the SAVE-command (ref. section 10.10). In order to use or test a new setting in Normal Mode without permanently storing it, this can be achieved by using the EXIT n-command (ref. section 10.13).

Table 10-25: Available f (LP FILTER -3dB FREQUENCY) commands

Syntax	Response
f<SP><-3dBfreq><CR>	Changes the LP filter -3dB frequency for all sensors and axes
f<SP><-3dBfreq>','<sens><CR>	Changes the LP filter -3dB frequency for all axes of a specific sensor
f<SP><-3dBfreq>','<sens>','<axis><CR>	Changes the LP filter -3dB frequency for a specified sensor and axis

Table 10-26: Allowed values for <-3dBfreq> parameter for f (LP FILTER -3dB FREQUENCY) commands

<-3dBfreq>	Result
0	Will change LP filter -3dB frequency to 16Hz
1	Will change LP filter -3dB frequency to 33Hz
2	Will change LP filter -3dB frequency to 66Hz
3	Will change LP filter -3dB frequency to 131Hz
4	Will change LP filter -3dB frequency to 262Hz

Table 10-27: Allowed values for <sens> parameter for f (LP FILTER -3dB FREQUENCY) commands

<sens>	Result
g	Will change LP filter -3dB frequency for the gyro(s)
a	Will change LP filter -3dB frequency for the accelerometer(s)
i	Will change LP filter -3dB frequency for the inclinometer(s)

Table 10-28: Allowed values for <axis> parameter for f (LP FILTER -3dB FREQUENCY) commands

<axis>	Result
x	Will change LP filter -3dB frequency for X-axis only
y	Will change LP filter -3dB frequency for Y-axis only
z	Will change LP filter -3dB frequency for Z-axis only

Table 10-29: Error messages for f (LP FILTER -3dB FREQUENCY) commands

Error	Message	Possible reason
E001	UNKOWN COMMAND	Command is incorrectly entered
E002	INCORRECT NUMBER OF PARAMETERS	Too many or too few parameters, use of comma between command and first parameter
E003	INVALID PARAMETER	Value of parameter outside valid range

```
>f 2,a,x
ACCELEROMETER LP FILTER -3dB FREQUENCY, X-AXIS [Hz] = 66
>
```

Figure 10-28: Example of response from f (LP FILTER -3dB FREQUENCY) command

```
>f 3
GYRO LP FILTER -3dB FREQUENCY, X-AXIS [Hz] = 131
GYRO LP FILTER -3dB FREQUENCY, Y-AXIS [Hz] = 131
GYRO LP FILTER -3dB FREQUENCY, Z-AXIS [Hz] = 131
ACCELEROMETER LP FILTER -3dB FREQUENCY, X-AXIS [Hz] = 131
ACCELEROMETER LP FILTER -3dB FREQUENCY, Y-AXIS [Hz] = 131
ACCELEROMETER LP FILTER -3dB FREQUENCY, Z-AXIS [Hz] = 131
INCLINOMETER LP FILTER -3dB FREQUENCY, X-AXIS [Hz] = 131
INCLINOMETER LP FILTER -3dB FREQUENCY, Y-AXIS [Hz] = 131
INCLINOMETER LP FILTER -3dB FREQUENCY, Z-AXIS [Hz] = 131
>
```

Figure 10-29: Example of response from f (LP FILTER -3dB FREQUENCY) command

```
>f 1,g
GYRO LP FILTER -3dB FREQUENCY, X-AXIS [Hz] = 33
GYRO LP FILTER -3dB FREQUENCY, Y-AXIS [Hz] = 33
GYRO LP FILTER -3dB FREQUENCY, Z-AXIS [Hz] = 33
>
```

Figure 10-30: Example of response from f (LP FILTER -3dB FREQUENCY) command

```
>f 0,i
INCLINOMETER LP FILTER -3dB FREQUENCY [Hz] = 16
>
```

Figure 10-31: Example of response from f (LP FILTER -3dB FREQUENCY) command

10.9 m (SAMPLE RATE) command

General description: Changes the sample rate in Normal Mode. The sample rate is the same for all channels.

Note that the sample rate could be considered invalid, even if it has been entered correctly. This is because a valid sample rate also depends on the bit rate and chosen datagram content (ref. Table 6-8 and error message E007 in Table 10-32).

Note that sample rate should be considered together with filter settings in order to avoid issues with folding due to undersampling. No warnings will be issued by STIM318 if e.g. a high filter bandwidth and a low sample rate have been chosen.

Note that this change will only be effective until STIM318 is initialized, reset or powered off, unless the new setting has been stored in flash using the SAVE-command (ref. section 10.10). In order to use or test a new setting in Normal Mode without permanently storing it, this can be achieved by using the EXIT n-command (ref. section 10.13).

Table 10-30: Available m (SAMPLE RATE) command

Syntax	Response
m<SP><sampl.rate><CR>	Changes the sample rate in Normal Mode

Table 10-31: Allowed values for <sampl.rate> parameter for m (SAMPLE RATE) command

<sampl.rate>	Result
0	Will set sample rate to 125 samples /second
1	Will set sample rate to 250 samples /second
2	Will set sample rate to 500 samples /second
3	Will set sample rate to 1000 samples /second
4	Will set sample rate to 2000 samples /second
5	Will set sample to External Trigger

Table 10-32: Error messages for m (SAMPLE RATE) command

Error	Message	Possible reason
E001	UNKOWN COMMAND	Command is incorrectly entered
E002	INCORRECT NUMBER OF PARAMETERS	Too many or too few parameters, use of comma between command and first parameter
E003	INVALID PARAMETER	Value of parameter outside valid range
E007	DATAGRAM WILL BE TOO LONG TO TRANSMIT	Combination of bit-rate, sample rate and datagram content results in a datagram that cannot be transmitted

```
>m 2
SAMPLE RATE [samples/s] = 500
>
```

Figure 10-32: Example of response from m (SAMPLE RATE) command

```
>m 5
SAMPLE RATE = EXTERNAL TRIGGER
>
```

Figure 10-33: Example of response from m (SAMPLE RATE) command

10.10 g (GYRO G-COMP) command

General description: Changes the compensation parameters for the gyro g-compensation of bias and/or scale-factor. Refer to section 8.4.2.2.6 for a description of this functionality.

Table 10-33: Available g (GYRO G-COMP) commands

Syntax	Response
g<SP><StdComp><CR>	Changes the gyro g-compensation to one of the defined standard configurations. The cut-off frequency of the g-compensation LP-filter will be set to 0.01Hz. Gyro g-compensation will be applied to all axes.
g<SP><StdComp>','<FilterCutoff><CR>	Changes the gyro g-compensation to one of the defined standard configurations, but sets the g-compensation LP-filter to a non-standard cut-off frequency. Gyro g-compensation will be applied to all axes.
g<SP><BiasSource>','<BiasFilter>','<ScaleSource>','<ScaleFilter><CR>	Changes the gyro g-compensation to a user-defined gyro g-compensation configuration, but leaves the g-compensation LP-filter unchanged. Gyro g-compensation will be applied to all axes.
g<SP><BiasSource>','<BiasFilter>','<ScaleSource>','<ScaleFilter>','<FilterCutoff><CR>	Changes the gyro g-compensation to a user-defined gyro g-compensation configuration, including the g-compensation LP-filter. Gyro g-compensation will be applied to all axes.
g<SP><Xonoff>','<Yonoff>','<Zonoff>','<BiasSource>','<BiasFilter>','<ScaleSource>','<ScaleFilter><CR>	Changes the gyro g-compensation to a user-defined gyro g-compensation configuration, but leaves the g-compensation LP-filter unchanged. Gyro g-compensation will be applied to specific axes.
g<SP><Xonoff>','<Yonoff>','<Zonoff>','<BiasSource>','<BiasFilter>','<ScaleSource>','<ScaleFilter>','<FilterCutoff><CR>	Changes the gyro g-compensation to a user-defined gyro g-compensation configuration, including the g-compensation LP-filter. Gyro g-compensation will be applied to specific axes.

Table 10-34 : Allowed values for <StdComp> for g (GYRO G-COMP) command

<StdComp>	Bias		Scale-factor	
	BiasSource	BiasFilter	ScaleSource	ScaleFilter
0	OFF	-	OFF	-
1 ¹⁾	OFF	-	ACC	OFF
2	OFF	-	ACC	ON
3 ¹⁾	ACC	OFF	OFF	-
4	ACC	ON	OFF	-
5 ¹⁾	INC	OFF	OFF	-
6	INC	ON	OFF	-
7 ¹⁾	ACC	OFF	ACC	OFF
8 ¹⁾	ACC	ON	ACC	OFF
9 ¹⁾	INC	OFF	ACC	OFF
a ¹⁾	INC	ON	ACC	OFF
b	ACC	ON	ACC	ON
c	INC	ON	INC	ON

¹⁾ A warning will be issued if gyro output unit has not been chosen as delayed (ref. section 8.4.2.2.1 and 10.7)

Table 10-35 : Allowed range for <FilterCutoff> for g (GYRO G-COMP) command

<FilterCutoff>	Unit	Minimum	Standard	Maximum
<FilterCutoff>	Hz	0.001	0.01	5.00

Decimal point = '.'. Format can be integer, scientific or decimal.

Table 10-36 : Allowed values for <ScaleSource> and <BiasSource> for g (GYRO G-COMP) command

<BiasSource> <ScaleSource>	Result
0	Gyro g-compensation turned OFF
1	Gyro g-compensation uses data from accelerometers
2	Gyro g-compensation uses data from inclinometers

Table 10-37 : Allowed values for <ScaleFilter> and <BiasFilter> for g (GYRO G-COMP) command

<BiasFilter> <ScaleFilter>	Result
0	Gyro g-compensation LP-filter not applied (OFF)
1	Gyro g-compensation LP-filter applied (ON)

Table 10-38 : Allowed values for <Xonoff>, <Yonoff> and <Zonoff> for g (GYRO G-COMP) command

<Xonoff> <Yonoff> <Zonoff>	Result
0	Gyro g-compensation is not applied to specific axis (OFF)
1	Gyro g-compensation is applied to specific axis (ACC or INC)

Table 10-39: Error messages for g (GYRO G-COMP) command

Error	Message	Possible reason
E001	UNKOWN COMMAND	Command is incorrectly entered
E002	INCORRECT NUMBER OF PARAMETERS	Too many or too few parameters, use of comma between command and first parameter
E003	INVALID PARAMETER	Value of parameter outside valid range

```

>g 1
GYRO G-COMPENSATION:
BIAS SOURCE, X-AXIS = OFF
BIAS G-COMP LP-FILTER, X-AXIS = NA
SCALE SOURCE, X-AXIS = ACC
SCALE G-COMP LP-FILTER, X-AXIS = OFF
BIAS SOURCE, Y-AXIS = OFF
BIAS G-COMP LP-FILTER, Y-AXIS = NA
SCALE SOURCE, Y-AXIS = ACC
SCALE G-COMP LP-FILTER, Y-AXIS = OFF
BIAS SOURCE, Z-AXIS = OFF
BIAS G-COMP LP-FILTER, Z-AXIS = NA
SCALE SOURCE, Z-AXIS = ACC
SCALE G-COMP LP-FILTER, Z-AXIS = OFF
G-COMP LP-FILTER CUTOFF = 0.010 HZ
>

```

Figure 10-34: Example of response from g (GYRO G-COMP) command

```

>g 8,0,3
GYRO G-COMPENSATION: WARNING: DELAYED GYRO OUTPUT UNIT IS RECOMMENDED
BIAS SOURCE, X-AXIS = ACC
BIAS G-COMP LP-FILTER, X-AXIS = ON
SCALE SOURCE, X-AXIS = ACC
SCALE G-COMP LP-FILTER, X-AXIS = OFF
BIAS SOURCE, Y-AXIS = ACC
BIAS G-COMP LP-FILTER, Y-AXIS = ON
SCALE SOURCE, Y-AXIS = ACC
SCALE G-COMP LP-FILTER, Y-AXIS = OFF
BIAS SOURCE, Z-AXIS = ACC
BIAS G-COMP LP-FILTER, Z-AXIS = ON
SCALE SOURCE, Z-AXIS = ACC
SCALE G-COMP LP-FILTER, Z-AXIS = OFF
G-COMP LP-FILTER CUTOFF = 0.300 HZ
>

```

Figure 10-35: Example of response from g (GYRO G-COMP) command with warning

```

>g 2,1,1,0,0,5
GYRO G-COMPENSATION:
BIAS SOURCE, X-AXIS = INC
BIAS G-COMP LP-FILTER, X-AXIS = ON
SCALE SOURCE, X-AXIS = ACC
SCALE G-COMP LP-FILTER, X-AXIS = OFF
BIAS SOURCE, Y-AXIS = INC
BIAS G-COMP LP-FILTER, Y-AXIS = ON
SCALE SOURCE, Y-AXIS = ACC
SCALE G-COMP LP-FILTER, Y-AXIS = OFF
BIAS SOURCE, Z-AXIS = INC
BIAS G-COMP LP-FILTER, Z-AXIS = ON
SCALE SOURCE, Z-AXIS = ACC
SCALE G-COMP LP-FILTER, Z-AXIS = OFF
G-COMP LP-FILTER CUTOFF = 0.500 HZ
>

```

Figure 10-36: Example of response from g (GYRO G-COMP) command

```

>g 0,0,1,2,1,1,0
GYRO G-COMPENSATION:
BIAS SOURCE, X-AXIS = OFF
BIAS G-COMP LP-FILTER, X-AXIS = NA
SCALE SOURCE, X-AXIS = OFF
SCALE G-COMP LP-FILTER, X-AXIS = NA
BIAS SOURCE, Y-AXIS = OFF
BIAS G-COMP LP-FILTER, Y-AXIS = NA
SCALE SOURCE, Y-AXIS = OFF
SCALE G-COMP LP-FILTER, Y-AXIS = NA
BIAS SOURCE, Z-AXIS = INC
BIAS G-COMP LP-FILTER, Z-AXIS = ON
SCALE SOURCE, Z-AXIS = ACC
SCALE G-COMP LP-FILTER, Z-AXIS = OFF
G-COMP LP-FILTER CUTOFF = 0.500 HZ
>

```

Figure 10-37: Example of response from g (GYRO G-COMP) command

10.11 b (BIAS TRIM OFFSET) command

General description: Changes bias trim offsets.

Refer to section 8.4.2.3 for a description of this functionality.

Table 10-40: Available b (BIAS TRIM OFFSET) commands

Syntax	Response
b<SP><BiasTrimOffset><CR>	Sets the bias trim offsets for all sensors and axes. Command is useful when clearing all bias trim offsets
b<SP><BiasTrimOffset>','<sens><CR>	Sets the bias trim offsets for a specific sensor, all axes. Command is useful when clearing all bias trim offsets for a given sensor
b<SP><DeltaBiasTrimOffset>','<sens>','<axis><CR>	Adjusts the bias trim offsets for a specific sensor and axis. <DeltaBiasTrimOffset> is added to the current bias trim offset
b<SP><RefInfo>','r'<CR>	Sets the Reference Information. <RefInfo> is a 32-bit unsigned integer that can be used to define a reference to the bias trim offsets, e.g. a date code

If the bias trim offsets are programmed outside the specified min or max limits, ref. Table 6-3, Table 6-4 and Table 6-5, the relevant bias trim offsets will be set to min or max, whichever is the closest to the requested value and flagged by error message E008, ref. Table 10-44.

Table 10-41: Allowed values for <sens> parameter for b (BIAS TRIM OFFSET) commands

<sens>	Result
g	Will change bias trim offset for the gyro(s)
a	Will change bias trim offset for the accelerometer(s)
i	Will change bias trim offset for the inclinometer(s)

Table 10-42: Unit of <BiasTrimOffset> and <DeltaBiasTrimOffset> for the different values of <sens> for the b (BIAS TRIM OFFSET) commands

<sens>	Unit of <BiasTrimOffset> and <DeltaBiasTrimOffset>
g	[°/s]
a	[g]
i	[g]

Table 10-43: Allowed values for <axis> parameter for b (BIAS TRIM OFFSET) command

<axis>	Result
x	Will change bias trim offset for X-axis only
y	Will change bias trim offset for Y-axis only
z	Will change bias trim offset for Z-axis only

Table 10-44: Error messages for b (BIAS TRIM OFFSET) command

Error	Message	Possible reason
E001	UNKOWN COMMAND	Command is incorrectly entered
E002	INCORRECT NUMBER OF PARAMETERS	Too many or too few parameters, use of comma between command and first parameter
E003	INVALID PARAMETER	Value of parameter outside valid range
E008	BIAS TRIM OFFSET(S) SET TO MIN OR MAX	Requested change(s) reduced due to violation of min/max limits for bias trim offset(s)

```
>b 0
BIAS TRIM OFFSET:
GYRO X-AXIS [°/s ] = 0.00000
GYRO Y-AXIS [°/s ] = 0.00000
GYRO Z-AXIS [°/s ] = 0.00000
ACCELEROMETER X-AXIS [g ] = 0.000000
ACCELEROMETER Y-AXIS [g ] = 0.000000
ACCELEROMETER Z-AXIS [g ] = 0.000000
INCLINOMETER X-AXIS [g ] = 0.000000
INCLINOMETER Y-AXIS [g ] = 0.000000
INCLINOMETER Z-AXIS [g ] = 0.000000
>
```

Figure 10-38: Example of response from b (BIAS TRIM OFFSET) command

```
>b 0,a
BIAS TRIM OFFSET:
ACCELEROMETER X-AXIS [g ] = 0.000000
ACCELEROMETER Y-AXIS [g ] = 0.000000
ACCELEROMETER Z-AXIS [g ] = 0.000000
>
```

Figure 10-39: Example of response from b (BIAS TRIM OFFSET) command

```
>b 0.001,g,x
BIAS TRIM OFFSET:
GYRO X-AXIS [°/s ] = 0.02443
>
```

Figure 10-40: Example of response from b (BIAS TRIM OFFSET) command

```
>b 2.3,i
BIAS TRIM OFFSET:
INCLINOMETER X-AXIS [g ] = 0.0200000
INCLINOMETER Y-AXIS [g ] = 0.0200000
INCLINOMETER Z-AXIS [g ] = 0.0200000

E008 BIAS TRIM OFFSET(S) SET TO MIN OR MAX
>
```

Figure 10-41: Example of response from b (BIAS TRIM OFFSET) command

```
>b 43639,r
BIAS TRIM OFFSET:
REFERENCE INFO = 43639
>
```

Figure 10-42: Example of response from b (BIAS TRIM OFFSET) command

10.12 s (SAVE) command

General description: Saves configuration parameters to flash. This will permanently change the configuration parameters and hence be valid after an initialization or power-off.

The flash used in STIM318 is specified to be capable of minimum 10,000 saves. A save-counter has been implemented and when the number of saves exceeds 10,000, there will be issued a warning. STIM318 will always attempt to save the configuration when receiving the s (SAVE) command regardless of the content of the save-counter.

Table 10-45: Available s (SAVE) command

Syntax	Response
s<CR>	Saves system parameters to flash. This command will require an additional confirmation prior to execution. Confirmation ("Y") to be responded in upper case letter. If transmission parameters have been changed (ref. TRANSMISSION PARAMETERS command, section 10.5) AND confirmation to the save-command is not "Y", then the transmission parameters, including bit-rate, will be reset to the previously saved settings NB: Do not turn off power until the ready-prompt (">") has been received

Table 10-46: Error messages for s (SAVE) command

Error	Message	Possible reason
E001	UNKOWN COMMAND	Command is incorrectly entered
E002	INCORRECT NUMBER OF PARAMETERS	Any characters between command and <CR>
E003	INVALID PARAMETER	Value of parameter outside valid range
E004	EXCEEDED MAXIMUM NUMBER OF SAVES	Warning appears when maximum number of saves has been exceeded (10,000 saves). STIM318 will always attempt to save the configuration when receiving the s (SAVE)-command.
E005	ERROR DURING SAVE	System parameters not successfully transferred to flash

```
>s
SYSTEM PARAMETERS WILL BE PERMANENTLY CHANGED. CONFIRM SAVE(Y/N): Y
SYSTEM PARAMETERS SUCCESSFULLY STORED IN FLASH.
NUMBER OF SAVES = 26
>
```

Figure 10-43: Example of response from s (SAVE) command when confirming save

```
>s
SYSTEM PARAMETERS WILL BE PERMANENTLY CHANGED. CONFIRM SAVE(Y/N): N
SAVE COMMAND ABORTED.
>
```

Figure 10-44: Example of response from s (SAVE) command when not confirming save

```
>s
SYSTEM PARAMETERS WILL BE PERMANENTLY CHANGED. CONFIRM SAVE(Y/N): y
SAVE COMMAND ABORTED.

E003 INVALID PARAMETER
>
```

Figure 10-45: Example of response from s (SAVE) command when not correctly responding to confirmation

10.13 x (EXIT) command

General description: Terminates Service Mode and returns to Normal Mode directly or via Init Mode (ref. Figure 8-6).

Table 10-47 : Available x (EXIT) command

Syntax	Response
x<SP><exit_to><CR>	Terminates Service Mode

Table 10-48 : Allowed values for <exit_to> for x (EXIT) command

<exit_to>	Result
n	Terminates Service Mode and return to Normal Mode. If system parameters have been changed compared to flash content, a confirmation is requested before exiting to Normal Mode ("Y" in upper case letter). There will be a 3 seconds hold-time between the transmitted command response and execution of the EXIT-command.
i	Terminates Service Mode and return to Init Mode. If system parameters have been changed compared to flash content, a confirmation is requested before exiting to Normal Mode ("Y" in upper case letter). There will be a 3 seconds hold-time between the transmitted command response and execution of the EXIT-command. NB: Changes made to system parameters, but not saved, will be overwritten by the data already stored in flash when entering Init Mode.
N	Terminates Service Mode and return immediately to Normal Mode (without confirmation if system parameters have been changed compared to flash and without any hold-time)
I	Terminates Service Mode and return immediately to Init Mode (without confirmation if system parameters have been changed compared to flash and without any hold-time). NB: Changes made to system parameters, but not saved, will be overwritten by the data already stored in flash when entering Init Mode.

Table 10-49: Error messages for x (EXIT) command

Error	Message	Possible reason
E001	UNKOWN COMMAND	Command is incorrectly entered
E002	INCORRECT NUMBER OF PARAMETERS	Too many or too few parameters, use of comma between command and first parameter
E003	INVALID PARAMETER	Value of parameter outside valid range

```
>x n
SYSTEM RETURNING TO NORMAL MODE.
```

Figure 10-46: Example of response from x n (EXIT) command when system parameters match contents of flash

```
>x i
SYSTEM RETURNING TO INIT MODE.
```

Figure 10-47: Example of response from x i (EXIT) command when system parameters match contents of flash

```
>x n
CURRENT SYSTEM PARAMETERS DO NOT MATCH FLASH CONTENT. CONFIRM EXIT(Y/N): Y
SYSTEM RETURNING TO NORMAL MODE.
```

Figure 10-48: Example of response from x n (EXIT) command after system parameters have been changed but not saved with confirmed EXIT

```
>x i
CURRENT SYSTEM PARAMETERS DO NOT MATCH FLASH CONTENT. CONFIRM EXIT(Y/N): N
>
```

Figure 10-49: Example of response from x i (EXIT) command after system parameters have been changed but not saved with confirmed not to EXIT

```
>x n
CURRENT SYSTEM PARAMETERS DOES NOT MATCH FLASH CONTENT. CONFIRM EXIT(Y/N): n

E003 INVALID PARAMETER

>
```

Figure 10-50: Example of response from x n (EXIT) command after system parameters have been changed but not saved with incorrect response to confirmation.

10.14 z (RESTORE TO FACTORY SETTINGS) command

General description: Restores the configuration of the unit to its factory settings. Note: BTO-parameters are not reset

Table 10-50: Available z (RESTORE TO FACTORY SETTINGS) commands

Syntax	Response
z<CR>	Restores the configuration of the unit to its factory settings. NB: The restored configuration will not be permanent unless it is SAVED to flash before EXITing Service Mode, resetting the unit or turning off power.
z<SP>,'s',<CR>	Restores the configuration of the unit to its factory settings and saves the configuration to flash. NB: Do not turn off power until the ready-prompt (">") has been received

Table 10-51: Error messages for z (RESTORE TO FACTORY SETTINGS) command

Error	Message	Possible reason
E001	UNKOWN COMMAND	Command is incorrectly entered
E002	INCORRECT NUMBER OF PARAMETERS	Any characters between command and <CR>
E003	INVALID PARAMETER	Value of parameter outside valid range
E004	EXCEEDED MAXIMUM NUMBER OF SAVES	Warning appears when maximum number of saves has been exceeded (10,000 saves). STIM318 will always attempt to save the configuration when receiving the s (SAVE)-command.
E005	ERROR DURING SAVE	System parameters not successfully transferred to flash

```
>z
RESTORE TO FACTORY SETTINGS.
CONFIRM CHANGE TO FACTORY SETTINGS (Y/N): Y

APPLYING FACTORY SETTINGS
FACTORY SETTINGS APPLIED. TO PERMANENTLY STORE THE SETTINGS, USE THE SAVE OR 'z s' COMMAND.

>
```

Figure 10-51: Example of response from z (RESTORE TO FACTORY SETTINGS) command with no change in transmission parameters.

```
>z
RESTORE TO FACTORY SETTINGS.
CONFIRM CHANGE TO FACTORY SETTINGS(Y/N): Y

THE TRANSMISSION CONFIGURATION WILL BE CHANGED TO:
BIT-RATE [bits/s] = 921600
DATA LENGTH = 8
STOP BITS = 1
PARITY = EVEN
PLEASE CONFIRM (Y/N): Y

APPLYING FACTORY SETTINGS
FACTORY SETTINGS APPLIED. TO PERMANENTLY STORE THE SETTINGS, USE THE SAVE OR 'z s' COMMAND.

>
```

Figure 10-52: Example of response from z (RESTORE TO FACTORY SETTINGS) command with change in transmission parameters.

```
>z s
RESTORE TO FACTORY SETTINGS.
CONFIRM CHANGE TO FACTORY SETTINGS AND SAVING(Y/N): Y

THE TRANSMISSION CONFIGURATION WILL BE CHANGED TO:
BIT-RATE [bits/s] = 921600
DATA LENGTH = 8
STOP BITS = 1
PARITY = EVEN
PLEASE CONFIRM (Y/N): Y

APPLYING FACTORY SETTINGS
FACTORY SETTINGS APPLIED AND SAVED.
NUMBER OF SAVES = 26

>
```

Figure 10-53: Example of response from z s (RESTORE TO FACTORY SETTINGS with save of configuration) command with change in transmission parameters.

10.15 ? (HELP) command

General description: Help function on the available commands in Service Mode.

Table 10-52: Available ? (HELP) commands

Syntax	Response
?<CR>	Lists the available parameters for this command
?<SP><hlp><CR>	Responds with information on the specified command

Table 10-53: Allowed values for <hlp> for ? (HELP) command

<hlp>	Result
i	Responds with information on the INFORMATION-command
a	Responds with information on the SINGLE-SHOT MEASUREMENT-command
c	Responds with information on the DIAGNOSTIC-command
d	Responds with information on the DATAGRAM FORMAT-command
t	Responds with information on the TRANSMISSION PARAMETERS-command
r	Responds with information on the LINE TERMINATION-command
u	Responds with information on the OUTPUT UNIT-command
f	Responds with information on the LP FILTER -3dB FREQUENCY-command
m	Responds with information on the SAMPLE RATE-command
g	Responds with information on the GYRO G-COMP-command
b	Responds with information on the BIAS TRIM OFFSET-command
s	Responds with information on the SAVE-command
x	Responds with information on the EXIT-command
z	Responds with information on the RESTORE TO FACTORY SETTINGS-command

Table 10-54: Error messages for ? (HELP) commands

Error	Message	Possible reason
E001	UNKOWN COMMAND	Command is incorrectly entered
E002	INCORRECT NUMBER OF PARAMETERS	Too many or too few parameters, use of comma between command and first parameter
E003	INVALID PARAMETER	Value of parameter outside valid range

```

>?
AVAILABLE PARAMETERS:
i: LISTS SPECIFIC INFORMATION
a: PERFORMS A SINGLE-SHOT MEASUREMENT
c: PERFORMS A DIAGNOSTIC OF THE UNIT
d: CHANGES DATAGRAM FORMAT
t : CHANGES TRANSMISSION PARAMETERS
r: CHANGES THE LINE TERMINATION
u : CHANGES OUTPUT UNIT
f: CHANGES LP FILTER -3DB FREQUENCY
m: CHANGES SAMPLE RATE
g: CHANGES CONFIGURATION OF GYRO G-COMPENSATION
b: CHANGES BIAS TRIM OFFSETS
s: SAVES CONFIGURATION DATA
x: EXITS SERVICE MODE
z: RESTORES FACTORY SETTINGS

>

```

Figure 10-54: Example of response from ? (HELP) command

```
>? i
i: LISTS THE PRODUCT CONFIGURATION DATA
i s: RETURNS THE SERIAL NUMBER
i n: RETURNS THE PRODUCT NAME
i x: RETURNS THE PART NUMBER
i a: RETURNS THE AXIS CONFIGURATION
i p: RETURNS THE FW CONFIGURATION AND REVISION
i m: RETURNS THE SAMPLE RATE
i f: RETURNS THE LP FILTER -3DB FREQUENCY
i d: RETURNS THE DATAGRAM FORMAT
i t: RETURNS THE TRANSMISSION PARAMETERS
i r: RETURNS THE LINE TERMINATION SETTING
i u: RETURNS THE OUTPUT UNIT
i g: RETURNS THE CONFIGURATION OF GYRO G-COMPENSATION
i b: RETURNS THE BIAS TRIM OFFSETS
i e: PRINTS THE EXTENDED ERROR INFORMATION FROM THE LAST DETECTED ERROR IN NORMAL MODE

>
```

Figure 10-55: Example of response from ? i (HELP on INFORMATION) command

```
>? a
a: PERFORMS A SINGLE-SHOT MEASUREMENT

>
```

Figure 10-56: Example of response from ? a (HELP ON SINGLE-SHOT MEASUREMENT) command

```
>? c
c: PERFORMS A DIAGNOSTIC OF THE UNIT

>
```

Figure 10-57: Example of response from ? c (HELP on DIAGNOSTIC) command

```
>? d
d <type>','<term>: CHANGES THE DATAGRAM FORMAT
  ALLOWED VALUES FOR <type>:
    0 = ID, RATE, COUNTER, LATENCY, CRC
    1 = ID, RATE, ACCELERATION, COUNTER, LATENCY, CRC
    2 = ID, RATE, INCLINATION, COUNTER, LATENCY, CRC
    3 = ID, RATE, ACCELERATION, INCLINATION, COUNTER, LATENCY, CRC
    4 = ID, RATE, TEMPERATURE, COUNTER, LATENCY, CRC
    5 = ID, RATE, ACCELERATION, TEMPERATURE, COUNTER, LATENCY, CRC
    6 = ID, RATE, INCLINATION, TEMPERATURE, COUNTER, LATENCY, CRC
    7 = ID, RATE, ACCELERATION, INCLINATIONS, TEMPERATURE, COUNTER, LATENCY, CRC
  ALLOWED VALUES FOR <term>:
    0 = NONE
    1 = <CR><LF>

>
```

Figure 10-58: Example of response from ? d (DATAGRAM TRANSMISSION MODE AND TERMINATION) command

```

>? t
t <bit-rate code>['','<bit-rate>]: CHANGES THE BIT-RATE [bits/s]
t <bit-rate code>['','<bit-rate>'],'<stop bits>','<parity>: CHANGES THE BIT-RATE [bits/s], NUMBER OF STOP-BITS AND PARITY
  ALLOWED VALUES FOR <bit-rate code>:
    0 = 377400
    1 = 460800
    2 = 921600
    3 = 1843200
    f = USER-DEFINED
  <bit-rate> MUST ONLY BE INCLUDED WHEN <bit-rate code> = f
  ALLOWED RANGE FOR <bit-rate>:
    1500 – 5023000 (INTEGER VALUE). SEE STIM318 DATASHEET FOR LIMITATIONS
  ALLOWED VALUES FOR <stop bits>:
    1 = 1
    2 = 2
  ALLOWED VALUES FOR <parity>:
    0 = NONE
    1 = ODD
    2 = EVEN
>
  
```

Figure 10-59: Example of response from ? t (HELP on TRANSMISSION PARAMETERS) command

```

>? r
r <on/off>: TURNS LINE TERMINATION ON OR OFF
  ALLOWED VALUES FOR <on/off>:
    0 = OFF
    1 = ON
>
  
```

Figure 10-60: Example of response from ? r (HELP on LINE TERMINATION) command

```

>? u
u <sens>','<unit>: CHANGES OUTPUT UNIT
  ALLOWED VALUES FOR <sens>:
    g = GYRO
    a = ACCELEROMETER
    i = INCLINOMETER
  ALLOWED VALUES FOR u,g,<unit>:
    0 = ANGULAR RATE
    1 = INCREMENTAL ANGLE
    2 = AVERAGE ANGULAR RATE
    3 = INTEGRATED ANGLE
    8 = ANGULAR RATE - DELAYED
    9 = INCREMENTAL ANGLE - DELAYED
    a = AVERAGE ANGULAR RATE - DELAYED
    b = INTEGRATED ANGLE - DELAYED
  ALLOWED VALUES FOR u,a,<unit>:
    0 = ACCELERATION
    1 = INCREMENTAL VELOCITY
    2 = AVERAGE ACCELERATION
  ALLOWED VALUES FOR u,i,<unit>:
    0 = ACCELERATION
    1 = INCREMENTAL VELOCITY
    2 = AVERAGE ACCELERATION
>
  
```

Figure 10-61: Example of response from ? u (HELP on OUTPUT UNIT) command

```
>? f
f <-3dBfreq>: CHANGES THE LP FILTER -3DB FREQUENCY [Hz] FOR ALL SENSORS AND AXES
f <-3dBfreq>',<sens>: CHANGES THE LP FILTER -3DB FREQUENCY [Hz] FOR ALL AXES OF SPECIFIED SENSOR
f <-3dBfreq>',<sens>',<axis>: CHANGES THE LP FILTER -3DB FREQUENCY [Hz] FOR A SPECIFIC SENSOR AND AXIS
  ALLOWED VALUES FOR <-3dBfreq>:
    0 = 16
    1 = 33
    2 = 66
    3 = 131
    4 = 262
  ALLOWED VALUES FOR <sens>:
    g = GYRO(S)
    a = ACCELEROMETER(S)
    i = INCLINOMETER(S)
  ALLOWED VALUES FOR <axis>:
    x = X-AXIS
    y = Y-AXIS
    z = Z-AXIS
>
```

Figure 10-62: Example of response from ? f (HELP on LP FILTER -3dB FREQUENCY) command

```
>? m
m <sampl.rate>: CHANGES THE SAMPLE RATE [samples/s]
  ALLOWED VALUES FOR <sampl.rate>
    0 = 125
    1 = 250
    2 = 500
    3 = 1000
    4 = 2000
    5 = EXTERNAL TRIGGER
>
```

Figure 10-63: Example of response from ? m (HELP on SAMPLE RATE) command

```

>? g
g <StdComp>: CHANGES GYRO G-COMP TO A PRE-DEFINED CONFIGURATION
g <StdComp>,<FilterCutoff>: CHANGES GYRO G-COMP TO A PRE-DEFINED CONFIG., BUT SPECIAL LP-FILTER CUTOFF
g <BiasSource>, <BiasFilter>,<ScaleSource>,<ScaleFilter>[,<FilterCutoff>]: CHANGES CONFIGURATION OF GYRO-G-COMP
g <Xonoff><Yonoff><Zonoff><BiasSource>, <BiasFilter>,<ScaleSource>,<ScaleFilter>[,<FilterCutoff>]: CHANGES
CONFIGURATION OF GYRO-G-COMP ON SPECIFIED AXES
  ALLOWED VALUES FOR <StdComp>:
    0 = <BiasSource> = 0, <BiasFilter> = 0, <ScaleSource> = 0, <ScaleFilter> = 0 (NO GYRO G-COMP)
    1 = <BiasSource> = 0, <BiasFilter> = 0, <ScaleSource> = 1, <ScaleFilter> = 0
    2 = <BiasSource> = 0, <BiasFilter> = 0, <ScaleSource> = 1, <ScaleFilter> = 1, <FilterCutoff> = 0.01
    3 = <BiasSource> = 1, <BiasFilter> = 0, <ScaleSource> = 0, <ScaleFilter> = 0
    4 = <BiasSource> = 1, <BiasFilter> = 1, <ScaleSource> = 0, <ScaleFilter> = 0, <FilterCutoff> = 0.01
    5 = <BiasSource> = 2, <BiasFilter> = 0, <ScaleSource> = 0, <ScaleFilter> = 0
    6 = <BiasSource> = 2, <BiasFilter> = 1, <ScaleSource> = 0, <ScaleFilter> = 0, <FilterCutoff> = 0.01
    7 = <BiasSource> = 1, <BiasFilter> = 0, <ScaleSource> = 1, <ScaleFilter> = 0
    8 = <BiasSource> = 1, <BiasFilter> = 1, <ScaleSource> = 1, <ScaleFilter> = 0, <FilterCutoff> = 0.01
    9 = <BiasSource> = 2, <BiasFilter> = 0, <ScaleSource> = 1, <ScaleFilter> = 0
    a = <BiasSource> = 2, <BiasFilter> = 1, <ScaleSource> = 1, <ScaleFilter> = 0, <FilterCutoff> = 0.01
    b = <BiasSource> = 1, <BiasFilter> = 1, <ScaleSource> = 1, <ScaleFilter> = 1, <FilterCutoff> = 0.01
    c = <BiasSource> = 2, <BiasFilter> = 1, <ScaleSource> = 2, <ScaleFilter> = 1, <FilterCutoff> = 0.01
  ALLOWED RANGE FOR <FilterCutoff>
    0.010 – 5.000 (ENTERED VALUE IS IN [Hz])
  ALLOWED VALUES FOR <BiasSource> and <ScaleSource>:
    0 = OFF (NO G-COMP)
    1 = ACCELEROMETER
    2 = INCLINOMETER
  ALLOWED VALUES FOR <BiasFilter> and <ScaleFilter>:
    0 = GYRO G-COMP LP-FILTER NOT IN USE (OFF)
    1 = GYRO G-COMP LP-FILTER IN USE (ON)
  ALLOWED VALUES FOR <Xonoff>, <Yonoff> and <Zonoff>:
    0 = NO GYRO G-COMP FOR SPECIFIC AXIS (OFF)
    1 = GYRO G-COMP FOR SPECIFIC AXIS (ON)
>

```

Figure 10-64: Example of response from ? g (HELP on GYRO G-COMP) command

```

>? b
b <BiasTrimOffset>: CHANGES BIAS TRIM OFFSET FOR ALL SENSORS AND ALL AXES TO <BiasTrimOffset>
b <BiasTrimOffset>,<Sensor>: CHANGES BIAS TRIM OFFSET FOR ALL AXES OF SPECIFIED SENSOR TO <BiasTrimOffset>
b <DeltaBiasTrimOffset>,<Sensor>, <Axis>: ADJUSTS BIAS TRIM OFFSET FOR SPECIFIED SENSOR AND AXIS BY
<DeltaBiasTrimOffset>
b <RefInfo>,<r>: DEFINES REFERENCE INFO FOR BIAS TRIM OFFSET. <RefInfo> IS A 32-BIT UNSIGNED INTEGER
  ALLOWED VALUES FOR <Sensor>:
    g = GYRO(S)
    a = ACCELEROMETER(S)
    i = INCLINOMETER(S)
  ALLOWED VALUES FOR <axis>:
    x = X-AXIS
    y = Y-AXIS
    z = Z-AXIS
  ALLOWED RANGE FOR <BiasTrimOffset>:
    GYROS [°/s]: -1.00000 TO 1.00000
    ACCELEROMETERS [g]: -0.100000 TO 0.100000
    INCLINOMETERS [g]: -0.0200000 TO 0.0200000
>

```

Figure 10-65: Example of response from ? b (HELP on BIAS TRIM OFFSET) command

```
>? s
s: SAVES SYSTEM PARAMETERS TO FLASH
>
```

Figure 10-66: Example of response from ? s (HELP on SAVE) command

```
>? x
x n: EXITS SERVICE MODE AND RETURNS TO NORMAL MODE
x i: EXITS SERVICE MODE AND RETURNS TO INIT MODE
x N: EXITS SERVICE MODE AND RETURNS IMMEDIATELY TO NORMAL MODE
x I: EXITS SERVICE MODE AND RETURNS IMMEDIATELY TO INIT MODE
NB: NON-MAVED SYSTEM PARAMETERS WILL BE OVERWRITTEN BY STORED CONTENT IN FLASH
WHEN EXITING TO INIT MODE
>
```

Figure 10-67: Example of response from ? x (HELP on EXIT) command

```
? z
z: RESTORES FACTORY SETTINGS
>
```

Figure 10-68: Example of response from ? z (HELP on RESTORE TO FACTORY SETTINGS) command

11 COMMANDS IN BIAS TRIM OFFSET MODE

Several commands are available in Bias Trim Offset Mode to adjust or reset the bias trim offsets.

11.1 Acknowledgement for entering Bias Trim Offset Mode

After the "BTOMODE"-command has been received, the response as shown in Figure 11-1 is transmitted to acknowledge having entered Bias Trim Offset Mode:

```
#BTOMODE,240<CR>
```

Figure 11-1: Acknowledgement for entering Bias Trim Offset Mode

The number 240 in Figure 11-1 is the CRC of the response, ref. section 11.2.3

11.2 Command protocol for Bias Trim Offset Mode

The protocol is optimized for machine – machine communication. All communication is however in readable ASCII format.

11.2.1 Command string

- All commands start with a message start character, '\$'
- All characters must be in lower case letters
- All parameters are delimited by character: ',' (comma)
- Leading white space characters <SP> and <HT> are allowed in front of all parameters
- Decimal separator is ".", scientific notation is allowed.
- To ensure correct reception, last parameter is always an 8 bit CRC checksum (ref. section 11.2.3)
- All commands are terminated by ASCII character carriage return (<CR>)
- Maximum number of characters in command string (including <CR>) is 100

11.2.2 Response string

- All responses from the STIM318 starts with a start character '#'
- The first return value is the command
- All characters will be in lower case letters
- All data are delimited by character: ',' (comma)
- Second value is status of the executed command (0= OK, other = error), (ref. section 11.2.4)
- Number of extra return values are defined for each command
- Last value is always an 8 bit CRC checksum to ensure correct transmission (ref. section 11.2.3)
- All command responses are terminated by ASCII character carriage return (<CR>)

11.2.3 Checksum

Both the command string and the response string contain a checksum as the last parameter to ensure that the string content is transmitted correctly.

The Checksum is calculated as a Cyclic Redundancy Checksum (CRC) with polynomial $X^8 + X^2 + X + 1$, seed = 0x0FF.

The checksum is calculated from ASCII values of all the characters in the preceding string, including the start character ('\$' or '#') and the last comma in front of the checksum.

The checksum value is presented as an ASCII string with a decimal value "0" through "255"

```
$isn,28<CR>
#isn,0,N2558184602002,32<CR>
```

Figure 11-2: Example of response string with CRC checksum

11.2.4 Command status codes

The status parameter is reporting the result of decoding and processing of the given command. Table 11-1 lists the possible status codes. When status = 0 then there are no errors.

Table 11-1: List of possible status codes for commands

Status code	Reason
0	Command execution OK
1	Invalid command (\$ missing in start of command-string)
2	Incorrect CRC
3	Unknown command
4	Incorrect number of parameters
5	Invalid parameter(s)
6	Exceeded maximum number of saves
7	Error during save
8	Requested change(s) reduced due to violation of min/max limits for bias trim offset(s)

If more than one error occurs, the lowest status code will be in the command-response.

Example of invalid command: `ibto,160<CR>`
 Response to command: `#,1,180<CR>`

Figure 11-3: Example of response in case of invalid command (status code = 1)

Example of command with incorrect CRC: `$sbto,0.00123,12<CR>`
 Response to command: `#,2,139<CR>`

Figure 11-4: Example of response in case of incorrect CRC (status code = 2)

Example of command with unknown command: `$dbto,0.00123,0<CR>`
 Response to command: `#,3,158<CR>`

Figure 11-5: Example of response in case of unknown command (status code = 3)

Example of command with incorrect number of parameters: `$sbto,0.0123,g,y,0,2<CR>`
 Response to command: `#sbto,4,136<CR>`

Figure 11-6: Example of response in case of incorrect number of parameters (status code = 4)

Example of command with invalid parameter(s): `$sbto,0.0123,s,y, 60<CR>`
 Response to command: `#sbto,5,157<CR>`

Figure 11-7: Example of response in case of invalid parameter(s) (status code = 5)

Example of command when exceeded maximum number of saves occurs: `$save,33<CR>`
 Response to command: `#save,6,0,158<CR>`

Figure 11-8: Example of response in case of exceeded maximum number of saves (status code = 6)

Example of command when error during save occurs: `$save,33<CR>`
 Response to command: `#save,7,8848,163<CR>`

Figure 11-9: Example of response in case of error during save (status code = 7)

Example of command with requested change(s) reduced due to violation of min/max limits for bias trim offset(s):
`$sdbto,0.01388,-0.02425,0.01724,-1,1,1,0.0083054,0.0102123,-0.0045032,252<CR>`
 Response to command: `#sdbto,8,0.02311,0.00934,-0.54432,-0.100000,0.100000,0.100000,0.0183432,-0.0134233,-0.0033322,203<CR>`

Figure 11-10: Example of response in case of requested change(s) reduced due to violation of min/max limits for bias trim offset(s) (status code = 8)

11.3 Info commands

General description: Various commands to request information related to bias trim offset.

Table 11-2: Available info commands

Command	Comments
\$ibto	Returns the bias trim offsets
\$isv	Returns the number of remaining saves
\$irf	Returns the last programmed reference information
\$isn	Returns the product serial number of the device
\$ix	Returns the part number of the device

11.3.1 \$ibto

Purpose: Provide information about the bias trim offsets

Format: \$ibto,<CRC><CR>
Example of command: \$ibto,160<CR>
Example of response: #ibto,0.01388,-0.02425,0.01724,-0.036230,0.002872,0.015903,0.0083054,0.0102123,-0.00450326,198<CR>
Explanation of response:
1: ibto = command
2: Status of command execution: ref. Table 11-1
3: Gyro X-axis bias trim offset [°/s] (number format: decimal number with 5 decimals)
4: Gyro Y-axis bias trim offset [°/s] (number format: decimal number with 5 decimals)
5: Gyro Z-axis bias trim offset [°/s] (number format: decimal number with 5 decimals)
6: Accelerometer X-axis bias trim offset [g] (number format: decimal number with 6 decimals)
7: Accelerometer Y-axis bias trim offset [g] (number format: decimal number with 6 decimals)
8: Accelerometer Z-axis bias trim offset [g] (number format: decimal number with 6 decimals)
9: Inclinometer X-axis bias trim offset [g] (number format: decimal number with 7 decimals)
10: Inclinometer Y-axis bias trim offset [g] (number format: decimal number with 7 decimals)
11: Inclinometer Z-axis bias trim offset [g] (number format: decimal number with 7 decimals)
12: CRC-8 calculation

Figure 11-11: Specification and example of \$ibto command

11.3.2 \$isv

Purpose: Provide information about the number of remaining saves

Format: \$isv,<CRC><CR>
Example of command: \$isv,227<CR>
Example of response: #isv,0,9958,168<CR>
Explanation of response:
1: isv = command
2: Status of command execution: ref. Table 11-1
3: Number of remaining saves (number format: integer)
4: CRC-8 calculation

Figure 11-12: Specification and example of \$isv command

11.3.3 \$irf

Purpose: Provide information about last programmed reference information

Format: \$irf,223<CR>
Example of command: \$irf,223<CR> Example of response: #irf,43638,44<CR>
Explanation of response: 1: irf = command 2: Status of command execution: ref. Table 11-1 3: Reference information (number format: unsigned integer) 4: CRC-8 calculation

Figure 11-13: Specification and example of \$irf command

11.3.4 \$isn

Purpose: Provide information about product serial number

Format: \$isn,<CRC><CR>
Example of command: \$isn,28<CR> Example of response: #isn,0,N2558184602002,32<CR>
Explanation of response: 1: isn = command 2: Status of command execution: ref. Table 11-1 3: SERIAL NUMBER = N2558184602002 4: CRC-8 calculation

Figure 11-14: Specification and example of \$isn command

11.3.5 \$ix

Purpose: Provide information about part number and revision

Format: \$ix,<CRC><CR>
Example of command: \$ix,118<CR> Example of response: #ix,0,84792,-,133<CR>
Explanation of response: 1: ix = command 2: Status of command execution: ref. Table 11-1 3: PART NUMBER = 84972 4: Revision = - 5: CRC-8 calculation

Figure 11-15: Specification and example of \$ix command

11.4 Programming commands

General description: Various commands to program parameters related to bias trim offset.

Note: The programming commands do not permanently store the new values. The updated values will be in effect until the part is powered off or reset. To permanently store the new values, the \$save-command (SAVE) must be used after having updated the required parameters.

Table 11-3: Available programming commands

Command	Comments
\$sdbto	Adjust in bias trim offsets
\$sbto	Programs the bias trim offset(s)
\$srf	Programs the 4 bytes of reference information

11.4.1 \$sdbto

Purpose: Adjust the bias trim offsets

Format: \$sdbto,<Gyro dX>,<Gyro dY>,<Gyro dZ>,<Acc dX>,<Acc dY>,<Acc dZ>,<Inc dX>,<Inc dY>,<Inc dZ>,<CRC><CR>

Explanation of input parameters:

- <Gyro dX>: Required adjustment in bias trim offset for gyro X-axis [°/s]
- <Gyro dY>: Required adjustment in bias trim offset for gyro Y-axis [°/s]
- <Gyro dZ>: Required adjustment in bias trim offset for gyro Z-axis [°/s]
- <Acc dX>: Required adjustment in bias trim offset for accelerometer X-axis [g]
- <Acc dY>: Required adjustment in bias trim offset for accelerometer Y-axis [g]
- <Acc dZ>: Required adjustment in bias trim offset for accelerometer Z-axis [g]
- <Inc dX>: Required adjustment in bias trim offset for inclinometer X-axis [g]
- <Inc dY>: Required adjustment in bias trim offset for inclinometer Y-axis [g]
- <Inc dZ>: Required adjustment in bias trim offset for inclinometer Z-axis [g]

Example of command: \$sdbto,0.01388,-0.02425,0.01724,-0.036230,0.002872,0.015903,0.0083054,0.0102123,-0.0045032,41<CR>

Example of response: #sdbto,0,0.02311,0.00934,-0.54432,0.089453,0.002666,-0.053422,0.0183432,-0.0134233,-0.0033322,229<CR>

Explanation of response:

- 1: sdbto = command
- 2: Status of command execution: ref. Table 11-1
- 3: Actual programmed bias trim offset for gyro X-axis [°/s] (number format: decimal number with 5 decimals)
- 4: Actual programmed bias trim offset for gyro Y-axis [°/s] (number format: decimal number with 5 decimals)
- 5: Actual programmed bias trim offset for gyro Z-axis [°/s] (number format: decimal number with 5 decimals)
- 6: Actual programmed bias trim offset for accelerometer X-axis [g] (number format: decimal number with 6 decimals)
- 7: Actual programmed bias trim offset for accelerometer Y-axis [g] (number format: decimal number with 6 decimals)
- 8: Actual programmed bias trim offset for accelerometer Z-axis [g] (number format: decimal number with 6 decimals)
- 9: Actual programmed bias trim offset for inclinometer X-axis [g] (number format: decimal number with 7 decimals)
- 10: Actual programmed bias trim offset for inclinometer Y-axis [g] (number format: decimal number with 7 decimals)
- 11: Actual programmed bias trim offset for inclinometer Z-axis [g] (number format: decimal number with 7 decimals)
- 12: CRC-8 calculation

Figure 11-16: Specification and example of \$sdbto command

11.4.2 \$sbto

Purpose: Program the bias trim offset(s)

Format1: \$sbto,<BiasTrimOffset>,<CRC><CR>
 Format2: \$sbto,<BiasTrimOffset>,<SensorCluster>,<CRC><CR>
 Format3: \$sbto, <BiasTrimOffset>,<SensorCluster>,<Axis> ,<CRC><CR>

Explanation of input parameters:

<BiasTrimOffset>: New value of bias trim offset [°/s] or [g]

<SensorCluster>: Sensor cluster to be programmed. Valid entries are:

- g : gyro
- a : accelerometer
- i : inclinometer

<Axis>: Specific axis to be programmed. Valid entries are:

- x : X-axis
- y : Y-axis
- z : Z-axis

<CRC>: CRC-8 calculation

Example of command using format1: \$sbto,0,165<CR> (example clears bias trim offset for all axes)

Example of response using format1: #sbto,0,0.00000,0.00000,0.00000,0.00000,0.00000,0.00000,0.00000,0.00000,0.00000,177<CR>

Example of command using format2: \$sbto,0,a,125<CR> (example clears bias trim offset for all accelerometers)

Example of response using format2: #sbto,0,0.02311,0.00934,0.54432,0.00000,0.00000,0.00000,0.0183432,0.0134233,0.0033322,181<CR>

Example of command using format3: \$sbto,3.4e-03,g,y,128<CR> (example sets bias trim offset for gyro Y-axis to 0.0034°/s)

Example of response using format3: #sbto,0,0.02311,0.00340,0.54432,0.089453,0.002666,0.053422,0.0183432,0.0134233,0.0033322,209<CR>

Explanation of response:

- 1: sbto = command
- 2: Status of command execution: ref. Table 11-1
- 3: Actual programmed bias trim offset for gyro X-axis [°/s] (number format: decimal number with 5 decimals)
- 4: Actual programmed bias trim offset for gyro Y-axis [°/s] (number format: decimal number with 5 decimals)
- 5: Actual programmed bias trim offset for gyro Z-axis [°/s] (number format: decimal number with 5 decimals)
- 6: Actual programmed bias trim offset for accelerometer X-axis [g] (number format: decimal number with 6 decimals)
- 7: Actual programmed bias trim offset for accelerometer Y-axis [g] (number format: decimal number with 6 decimals)
- 8: Actual programmed bias trim offset for accelerometer Z-axis [g] (number format: decimal number with 6 decimals)
- 9: Actual programmed bias trim offset for inclinometer X-axis [g] (number format: decimal number with 7 decimals)
- 10: Actual programmed bias trim offset for inclinometer Y-axis [g] (number format: decimal number with 7 decimals)
- 11: Actual programmed bias trim offset for inclinometer Z-axis [g] (number format: decimal number with 7 decimals)
- 12: CRC-8 calculation

Figure 11-17: Specification and example of \$sbto command

11.4.3 \$srf

Purpose: Program the reference info

Format: \$srf,<RefInfo>,<CRC><CR>

Explanation of input parameters:

<RefInfo>: Reference information (format: 32-bit unsigned integer), e.g. a date code

<CRC>: CRC-8 calculation

Example of command: \$srf,43638,122<CR> (example shows programming of datecode for "June 22, 2019" (=43638))

Example of response: #srf,43638,39<CR>

Explanation of response:

- 1: srf = command
- 2: Status of command execution: ref. Table 11-1.
- 3: Actual programmed reference info
- 4: CRC-8 calculation

Figure 11-18: Specification and example of \$srf command

11.5 General commands

General description: Various general commands.

Table 11-4: Available general commands

Command	Comments
\$save	Saves updated parameters to flash memory
\$xn	Terminates Bias Trim Offset Mode and returns to Normal Mode

11.5.1 \$save

Purpose: Permanently store bias trim offset related parameters to flash memory

Format: \$save,<CRC><CR>
Example of command: \$save,33,<CR> Example of response: #save,0,9958,175<CR>
Explanation of response (format): 1: save = command 2: Status of command execution: ref. Table 11-1 3: Remaining number of saves 4: CRC-8 calculation

Figure 11-19: Specification and example of \$save command

11.5.2 \$xn

Purpose: Terminate Bias Trim Offset Mode and return to Normal Mode

Format: \$xn,<CRC><CR>
Example of command: \$xn,150,<CR> Example of response: #xn,0,125<CR>
Explanation of response (format): 1: xn = command 2: Status of command execution: ref. Table 11-1 3: CRC-8 calculation

Figure 11-20: Specification and example of \$xn command

12 MARKING

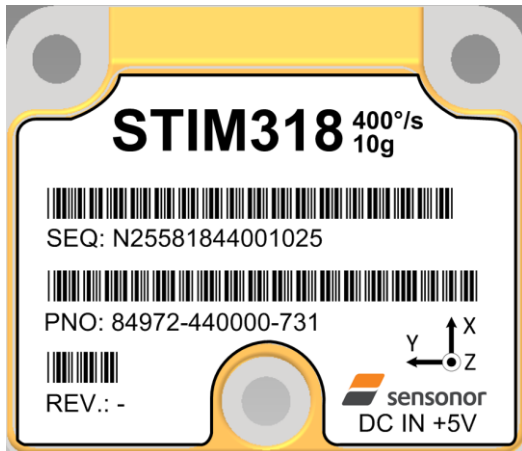

Figure 12-1: Example of marking of STIM318

13 CONFIGURATION / ORDERING INFORMATION

The STIM318 will be delivered according to the configuration code as shown below. All configuration parameters can be changed later in Service Mode, ref. section 8.4.2.3. A full list of configurable parameters can be found in Table 6-7.

Configuration parameters in **bold** letters show the standard option.

Range		Measurement						Output/RS422			
Prod_ID	-	Sample rate	Filter band-width	Gyro output unit	Acc. output unit	Incl. output unit	Gyro g-comp	-	Datagram	Bit-rate	Termination

Range STIM318		
Prod_ID	Gyro	Acc
85020	400°/s	10g

Range STIM318e		
Prod_ID	Gyro	Acc
84972	400°/s	10g

Sample rate:	
0 = 125 samples/s	
1 = 250 samples/s	
2 = 500 samples/s	
3 = 1000 samples/s	
4 = 2000 samples/s	
5 = External Trigger	

Filter bandwidth:	
0 = 16Hz	
1 = 33Hz	
2 = 66Hz	
3 = 131Hz	
4 = 262Hz	

Gyro output unit:	
0 = Angular Rate [°/s]	
1 = Incremental Angle [°/sample]	
2 = Average Angular Rate [°/s]	
3 = Integrated Angle [°]	
8 = Angular Rate [°/s] – delayed	
9 = Incremental Angle [°/sample] – delayed	
a = Average Angular Rate [°/s] – delayed	
b = Integrated Angle [°] - delayed	

Acc. output unit:	
0 = Acceleration [g]	
1 = Incremental Velocity [m/s/sample]	
2 = Average Acceleration [g]	
3 = Integrated Velocity [m/s]	

Incl. output unit:	
0 = Acceleration [g]	
1 = Incremental Velocity [m/s/sample]	
2 = Average Acceleration [g]	
3 = Integrated Velocity [m/s]	

	Bias		Scale-factor	
	Source	0.01Hz-filter	Source	0.01Hz-filter
0	OFF	-	OFF	-
1 ¹⁾	OFF	-	ACC	OFF
2	OFF	-	ACC	ON
3 ¹⁾	ACC	OFF	OFF	-
4	ACC	ON	OFF	-
5 ¹⁾	INC	OFF	OFF	-
6	INC	ON	OFF	-
7 ¹⁾	ACC	OFF	ACC	OFF
8 ¹⁾	ACC	ON	ACC	OFF
9 ¹⁾	INC	OFF	ACC	OFF
a ¹⁾	INC	ON	ACC	OFF
b	ACC	ON	ACC	ON
c	INC	ON	INC	ON

Datagram				
	Included data			
	Rate	Acceleration	Inclination	Temperature
0	YES	NO	NO	NO
1	YES	YES	NO	NO
2	YES	NO	YES	NO
3	YES	YES	YES	NO
4	YES	NO	NO	YES
5	YES	YES	NO	YES
6	YES	NO	YES	YES
7	YES	YES	YES	YES

Bit-rate:	
0 = 374400 bits/s	
1 = 460800 bits/s	
2 = 921600 bits/s	
3 = 1843200 bits/s	
f = User-defined ²⁾	

Termination		
	Line	Datagram
0	OFF	None
1	ON	None
2	OFF	<CR><LF>
3	ON	<CR><LF>

RS422 data configuration	
#Start bit	1
#Data bits	8
#Stop bits	1 ³⁾
Parity	None ³⁾

- 1) Delayed gyro output unit should be selected with this option
- 2) Bit-rate must be specified. See section 10.5 for limitations
- 3) Configuration can be changed in SERVICEMODE. See section 10.5

Example: 84972-413020-330 has the following configuration:

- Gyro range = 400°/s, accelerometer range = 10g
- Sample rate = 2000 samples/s
- Low-pass filter bandwidth = 33Hz
- Gyro output unit = Integrated Angle [°]
- Accelerometer output unit = Acceleration [g]
- Inclinator output unit = Average Acceleration [g]
- No g-/acc-compensation of bias and scale-factor
- Datagram containing Rate, Acceleration and Inclination
- Bit-rate = 1843200 bits/s
- Datagram Termination = None
- Line termination OFF

NOTES

Information furnished by Sensoror is believed to be accurate and reliable. However, no responsibility is assumed by Sensoror for its use, nor for any infringements of patents or other rights of third parties that may result from its use. Sensoror reserves the right to make changes without further notice to any products herein. Sensoror makes no warranty, representation or guarantee regarding the suitability of its products for any particular purpose, nor does Sensoror assume any liability arising out of the application or use of any product or circuit, and specifically disclaims any and all liability, including without limitation consequential or incidental damages. No license is granted by implication or otherwise under any patent or patent rights of Sensoror. Trademarks and registered trademarks are the property of their respective owners. Sensoror products are not intended for any application in which the failure of the Sensoror product could create a situation where personal injury or death may occur. Should Buyer purchase or use Sensoror products for any such unintended or unauthorized application, Buyer shall indemnify and hold Sensoror and its officers, employees, subsidiaries, affiliates, and distributors harmless against all claims, costs, damages, and expenses, and reasonable legal fees arising out of, directly or indirectly, any claim of personal injury or death associated with such unintended or unauthorized use, even if such claim alleges that Sensoror was negligent regarding the design or manufacture of the part.

Sensoror AS

Phone: +47 3303 5000 - Fax: +47 3303 5005

sales@sensoror.comwww.sensoror.com